

**EXHIBIT 1: STAFF REPORT**

**DATE:** HEARING Friday April 10, 2026

**RE:** Application No. for the request submitted by the Port of Port Angeles to vacate approximately 15,557 square feet of City right-of-way.

**LOCATION:** 914 - 1014 Marine Drive, Port Angeles, WA 98362.

**APPLICANT:** Port of Port Angeles

**OWNER:** City of Port Angeles

**PLANNER:** Angel Torres, Long Range & Special Projects Administrator | Associate Planner

**I. SUMMARY**

A street vacation petition was submitted by the Port of Port Angeles to vacate approximately 8150+/- square feet of City right-of-way within Blocks 105 and 110 of the Townsite of Port Angeles. The requested vacation area is located landward of Marine Drive and is proposed to be incorporated into adjoining industrial property under common ownership. This request is evaluated under Chapter 35.79 RCW, which governs the vacation of streets and requires action by ordinance of the legislative authority following a public hearing and recommendation.

**II. PROPOSAL**

**Property Description:** The petition requests the vacation of a narrow strip of City right-of-way located between Marine Drive and W 4th Street. The area functions as an internal segment within a larger industrial site and it is proposed to be incorporated into the Port's existing property holdings.

**Address:** 914-1014 Marine Dr.

**Property ID / Tax Parcel ID:** 01-0536, 01-0515, 01-0506, 01-0500, 01-0350, 01-0340, 01-0310, 01-0305, 01-0300

**Zoning:** IH, Zone Chapter 17.34 PAMC

**Comprehensive Plan Future Land Use Designation:** Industrial and Parks & Open Space

**Dimensions:** Vary

**Area:** Approximately 8150+/- Square Feet

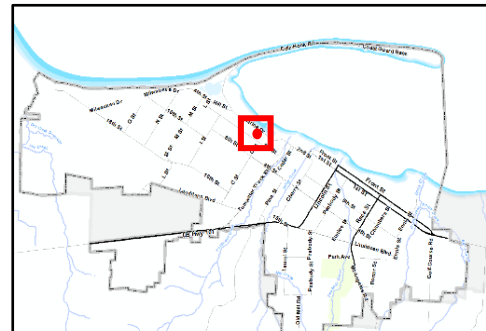

Figure 1: General location of the proposal

Exhibit 1: Staff Report |STV 26-0045 |Port of Port Angeles Street Vacation Petition

The proposal consolidates currently unimproved right-of-way into the Port's industrial holdings (lots) to facilitate maritime manufacturing expansion. The site is suited for Industrial Heavy (IH) uses, including structures up to 75 feet in height.



Figure 2: STV 26-0045 Site Map

**Land Description and Documentation**

All that portion of the former Chicago, Milwaukee, and St. Paul Railroad right-of-way lying between the north margin of said Railroad and the north margin of the alley within Block 110 and adjoining lots 1 through 4 of said block together with all that portion of the former Chicago, Milwaukee, and St. Paul Railroad right-of-way lying between the north margin of said Railroad right-of-way and the north margin of the alley within Block 105 and adjoining lots 1 Through 10 of said block.

**III. PROCEDURE**

On February 14, 2026, the Port of Port Angeles submitted a Street Vacation Petition application to vacate approximately 15,557 square feet of City right-of-way. The application was determined complete on February 18, 2026. During review, staff requested additional information related to valuation documentation and confirmation of abutting property ownership. Pursuant to Chapter 35.79 RCW, a public hearing is required prior to action by the legislative authority. PAMC 2.18.050(C) provides that the Hearing Examiner shall conduct a hearing and make findings,

## Exhibit 1: Staff Report | STV 26-0045 | Port of Port Angeles Street Vacation Petition

conclusions, and a recommendation to the City Council. Noticing materials are listed as Exhibit 4.

Notice of the application and public hearing was provided on the following dates and in the following manner:

- 3/19/2026: A notice sign was posted on Marine Drive adjacent the subject property subject property and on the City Hall Notice board.
- 3/19/26: Published in the Peninsula Daily News.
- 3/19/26: Mailed to all Property owners within 300' of subject property

The Hearing Examiner will conduct the public hearing and forward findings, conclusions, and a recommendation to the City Council. Final action on the street vacation will be taken by the City Council by ordinance in accordance with RCW 35.79.030.

#### IV. COMMENTS

---

##### **Public Comment:**

See Exhibit 3, Public Comment Memo. The written comment period remained open through April 2, 2026.

##### **City of Port Angeles Departmental Comments:**

Comments received from City of Port Angeles Departments have been incorporated into this report's findings and conditions.

#### V. FINDINGS OF FACT & STAFF ANALYSIS

---

Analysis and findings of fact from Department of Community and Economic Development (DCED) staff are based on the application materials, Port Angeles Municipal Code (PAMC), standards, plans, public comment, and other relevant materials available during the review period. The findings and analysis section of this report is a summary of the completed review by DCED staff.

##### **Public Use of Right-of-Way**

*Staff Analysis: The subject right-of-way has been evaluated to determine whether it is required for current or reasonably foreseeable public use, including vehicular circulation, pedestrian access, and public infrastructure. The right-of-way is not required for essential public use, subject to the retention of easements for utilities and public services.*

##### **Comprehensive Plan**

All Street Vacation Petitions must be consistent with the Port Angeles Comprehensive Plan. The following Port Angeles Comprehensive Plan policies are identified by Planning Staff to support the proposal in STV Application No. 26-0045:

##### Land Use Element:

## Exhibit 1: Staff Report |STV 26-0045 |Port of Port Angeles Street Vacation Petition

**Goal LU-5:** Industry and Maritime. Maintain and promote active use of industrial lands and waterfronts to maintain a diverse economy while stewarding the community's natural resources and desired development patterns.

**Policy LU-5.1:** Develop and promote a cooperative intergovernmental plan for the comprehensive development of industrial infrastructure and amenities to attract and support light and heavy industry.

**Policy LU-5.2:** Develop infrastructure that makes sites attractive and ready to develop, including transportation facilities and utilities at industrial parks. For example, proactively increase the capacity of utility lines.

Economic Development Element:

**Goal ED-1:** Diversify Port Angeles's economy, building on and expanding beyond the area's traditional natural resource industries to create and maintain a balanced local economy.

**Policy ED-1.10:** Support continued development of a strong maritime-related industry in the Port Angeles Harbor.

Transportation Element:

**Goal T-4:** Strengthen connections for industry and commerce while promoting prosperity, safety, and equity.

**Policy T-4.1:** Improve turning movements between the roadway network and industrial sites by prioritizing safety, accessibility, and efficiency, while considering traffic flow and maneuvering space.

Utilities and Public Services Element:

**Goal U-1:** Provide utility services efficiently and cost-effectively.

**Policy U-1.6:** Provide infrastructure to all industrial lands to encourage development.

**Policy U-1.9:** Utilize common utility corridors for urban service facilities located in shoreline areas.

**Policy U-1.10:** Promote the joint use of transportation rights-of-way and utility corridors for all forms of transportation, including non-motorized.

*Staff Analysis: The proposed street vacation is consistent with the Port Angeles Comprehensive Plan. The proposal consolidates an underutilized segment of right-of-way into an existing industrial site, supporting continued maritime and industrial use consistent with Goal LU-5 and Policy LU-5.1. The consolidation of land and infrastructure capacity supports industrial development and site readiness consistent with Policy LU-5.2 and Policy U-1.6. The proposal also supports Economic Development Goal ED-1 and Policy ED-1.10 by facilitating expansion of maritime-related industry within the Port Angeles Harbor. Transportation and utility policies, including T-4.1, U-1.9, and U-1.10, are addressed through the retention of easements and continued accommodation of infrastructure within the proposed vacated area.*

RCW 35.79 Criteria

## Exhibit 1: Staff Report |STV 26-0045 |Port of Port Angeles Street Vacation Petition

The City of Port Angeles relies on the Revised Code of Washington (RCW) sections that speak to street vacation and includes the requirements for petition, public noticing, public hearing, limitations, ordinance of vacation and title to vacated street or alley. These sections are within Chapter 35.79, RCW and are listed below:

35.79.010 – Petition by owners – Fixing time for hearing.

The owners of an interest in any real estate abutting upon any street or alley who may desire to vacate the street or alley, or any part thereof, may petition the legislative authority to make vacation, giving a description of the property to be vacated, or the legislative authority may itself initiate by resolution such vacation procedure.

The petition or resolution shall be filed with the city or town clerk, and, if the petition is signed by the owners of more than two-thirds of the property abutting upon the part of such street or alley sought to be vacated, legislative authority by resolution shall fix a time when the petition will be heard and determined by such authority or a committee thereof, which time shall not be more than sixty days nor less than twenty days after the date of the passage of such resolution.

*Staff Analysis: The Port of Port Angeles submitted a petition for the vacation of right-of-way within Blocks 105 and 110 of the Port Angeles Townsite on February 14, 2026. A public hearing before the City of Port Angeles Hearing Examiner is scheduled and noticed for April 10, 2026.*

35.79.020 – Notice of hearing. Objections prior to hearing.

Upon the passage of the resolution the city or town clerk shall give twenty days' notice of the pendency of the petition by a written notice posted in three of the most public places in the city or town and a like notice in a conspicuous place on the street or alley sought to be vacated. The said notice shall contain a statement that a petition has been filed to vacate the street or alley described in the notice, together with a statement of the time and place fixed for the hearing of the petition.

In all cases where the proceeding is initiated by resolution of the city or town council or similar legislative authority without a petition having been signed by the owners of more than two-thirds of the property abutting upon the part of the street or alley sought to be vacated, in addition to the notice hereinabove required, there shall be given by mail at least fifteen days before the date fixed for the hearing, a similar notice to the owners or reputed owners of all lots, tracts or parcels of land or other property abutting upon any street or alley or any part thereof sought to be vacated, as shown on the rolls of the county treasurer, directed to the address thereon shown:

PROVIDED, That if fifty percent of the abutting property owners file written objection to the proposed vacation with the clerk, prior to the time of hearing, the city shall be prohibited from proceeding with the resolution.

*Staff Analysis: Public notice was published on March 19, 2026, and posted in accordance with statutory requirements, satisfying the twenty-day notice period.*

35.79.030 – Hearing – Ordinance of vacation.

The hearing on such petition may be held before the legislative authority, before a committee thereof, or before a hearing examiner, upon the date fixed by resolution or at the time the hearing may be adjourned to. If the hearing is before a committee the same shall, following the hearing, report its recommendation on the petition to the legislative authority which may adopt or reject the recommendation.

If the hearing is held before a committee it shall not be necessary to hold a hearing on the petition before the legislative authority. If the hearing is before a hearing examiner, the hearing examiner shall, following the hearing, report its recommendation on the petition to the legislative authority, which may adopt or reject the recommendation:

PROVIDED, that the hearing examiner must include in its report to the legislative authority an explanation of the facts and reasoning underlying a recommendation to deny a petition. If a hearing is held before a hearing examiner, it shall not be necessary to hold a hearing on the petition before the legislative authority.

If the legislative authority determines to grant the petition or any part thereof, such city or town shall be authorized and have authority by ordinance to vacate such street, or alley, or any part thereof, and the ordinance may provide that it shall not become effective until the owners of property abutting upon the street or alley, or part thereof so vacated, shall compensate such city or town in an amount which does not exceed one-half the appraised value of the area so vacated. If the street or alley has been part of a dedicated public right-of-way for twenty-five years or more, or if the subject property or portions thereof were acquired at public expense, the city or town may require the owners of the property abutting the street or alley to compensate the city or town in an amount that does not exceed the full appraised value of the area vacated.

The ordinance may provide that the city retain an easement or the right to exercise and grant easements in respect to the vacated land for the construction, repair, and maintenance of public utilities and services. A certified copy of such ordinance shall be recorded by the clerk of the legislative authority and in the office of the auditor of the county in which the vacated land is located. One-half of the revenue received by the city or town as compensation for the area vacated must be dedicated to the acquisition, improvement, development, and related maintenance of public open space or transportation capital projects within the city or town.

## Exhibit 1: Staff Report |STV 26-0045| Port of Port Angeles Street Vacation Petition

*Staff Analysis: Per PAMC 2.18.050(C), the Hearing Examiner is authorized to conduct the hearing and provide a recommendation to the City Council. In accordance with RCW 35.79.030, staff requests a utility easement in favor of the City for the operation and maintenance of the existing 42-inch stormwater conveyance located within the subject area.*

## 35.79.035 – Limitations on vacations of streets abutting bodies of water – Procedure.

1. A city or town shall not vacate a street or alley if any portion of the street or alley abuts a body of fresh or saltwater unless:
  - a. The vacation is sought to enable the city or town to acquire the property for port purposes, beach or water access purposes, boat moorage or launching sites, park, public view, recreation, or educational purposes, or other public uses;
  - b. The city or town, by resolution of its legislative authority, declares that the street or alley is not presently being used as a street or alley and that the street or alley is not suitable for any of the following purposes: Port, beach or water access, boat moorage, launching sites, park, public view, recreation, or education; or
  - c. The vacation is sought to enable a city or town to implement a plan, adopted by resolution or ordinance, that provides comparable or improved public access to the same shoreline area to which the streets or alleys sought to be vacated abut, had the properties included in the plan not been vacated.

*Staff Analysis: The portion of right of way being petitioned for vacation is not abutting a fresh or saltwater body.*

2. Before adopting a resolution vacating a street or alley under subsection (1)(b) of this section, the city or town shall:
  - a. Compile an inventory of all rights-of-way within the city or town that abut the same body of water that is abutted by the street or alley sought to be vacated;
  - b. Conduct a study to determine if the street or alley to be vacated is suitable for use by the city or town for any of the following purposes: Port, boat moorage, launching sites, beach or water access, park, public view, recreation, or education;
  - c. Hold a public hearing on the proposed vacation in the manner required by this chapter, where in addition to the normal requirements for publishing notice, notice of the public hearing is posted conspicuously on the street or alley sought to be vacated, which posted notice indicates that the area is public access, it is proposed to be vacated, and that anyone objecting to the proposed vacation should attend the public hearing or send a letter to a particular official indicating his or her objection; and
  - d. Make a finding that the street or alley sought to be vacated is not suitable for any of the purposes listed under (b) of this subsection, and that the vacation is in the public interest.

## Exhibit 1: Staff Report |STV 26-0045 |Port of Port Angeles Street Vacation Petition

*Staff Analysis: The right of way to be vacated does not abut a body of water.*

3. No vacation shall be effective until the fair market value has been paid for the street or alley that is vacated. Moneys received from the vacation may be used by the city or town only for acquiring additional beach or water access, acquiring additional public view sites to a body of water, or acquiring additional moorage or launching sites.

*Staff Analysis: The right of way to be vacated is not abutting a body of water.*

35.79.040 – Title to vacated street or alley.

If any street or alley in any city or town is vacated by the city or town council, the property within the limits so vacated shall belong to the abutting property owners, one-half to each.

*Staff Analysis: The right of way to be vacated consists of only half the right of way and will be wholly provided to the petitioner property.*

35.79.050 – Vested rights not affected.

No vested rights shall be affected by the provisions of this chapter.

*Staff Analysis: The applicant has no permit applications currently requiring vested rights.*

### **Port Angeles Municipal Code**

The following PAMC provisions are seen as relevant to this application. Planning Staff provides comments under each provision as demonstration of the analysis that has occurred with the application review process and the findings of fact relevant to the application.

#### Title 18 – Growth Management

PAMC 18.02.090(A)(2): The following permits or approvals are specifically excluded from the procedures set forth in this title: Street vacations.

*Staff Analysis: Analysis indicates that street vacations are explicitly excluded from the procedures set forth in Title 18 and are processed in accordance with Chapter 35.79 RCW and applicable Hearing Examiner procedures.*

#### Title 2 – Administration and Personnel

PAMC 2.18.050(C): The Hearing Examiner is hereby authorized and directed to conduct a hearing and make findings, conclusions, and recommendations to the City Council on street vacations.

*Staff Analysis: The Hearing Examiner conducts a public hearing and makes findings, conclusions, and a recommendation to the City Council. The final authority to vacate public right-of-way remains a legislative action of the City Council.*

### Title 11 – Streets and Sidewalks

PAMC 11.12.010(G)(1): Right-of-way means: A dedicated or owned right-of-way or easement of the City within the boundaries of which may be located a street, highway, sidewalk, alley, avenue or other structure used for pedestrian or vehicular traffic or a utility structure or a utility structure or other related structure or feature. A right-of-way or easement is included within the definition of "right-of-way" whether such right-of-way or easement is currently used or not.

*Staff Analysis: The proposal involves City right-of-way subject to regulation under Title 11. Findings indicate that any vacation must account for existing and future transportation functions and utility infrastructure, including the retention of easements where necessary.*

### **Environmental Review**

WAC 197-11-800(2)(i) provides a categorical exemption for the “vacation of streets or roads.”

*Staff Analysis: The proposal is categorically exempt from environmental review under the State Environmental Policy Act (SEPA).*

### **Consistency**

RCW 35.79.030 provides that a hearing on a street vacation petition may be held before a hearing examiner, who shall report a recommendation to the legislative authority. The legislative authority may adopt or reject the recommendation and may, by ordinance, vacate the subject right-of-way. The ordinance may require compensation from abutting property owners and may retain easements for the construction, repair, and maintenance of public utilities and services.

*Staff Analysis: The proposal has been evaluated in accordance with Chapter 35.79 RCW. The Hearing Examiner is authorized to conduct the hearing and provide a recommendation, and the City Council retains final legislative authority. Conditions of approval ensure compliance with statutory provisions related to compensation and retention of easements.*

### **Recommendation**

It is the recommendation of the City staff that the Hearing Examiner forward a recommendation of approval to the City Council for Street Vacation Petition Application No. STV 26-0045, subject to the conclusions and conditions outlined in Section VI of this staff report. This recommendation is based on staff review of the application materials, Chapter 35.79 RCW, the Port Angeles Municipal Code, the Port Angeles Comprehensive Plan, and materials contained within the project record.

## VI. CONCLUSIONS & CONDITIONS

---

Having reviewed and considered the application materials, public comment, and all the information presented, the City staff recommends **approval of** Application No. STV 26-0045 for a Street Vacation Petition citing the following conclusions and recommended conditions:

1. The findings of fact are based on the application materials, Port Angeles Municipal Code, City standards, Comprehensive Plan policies and the full project record. The staff report constitutes the record of review.
2. The Hearing Examiner is authorized to conduct a public hearing and provide findings, conclusions, and a recommendation to the City Council pursuant to PAMC 2.18.050(C). Final action on the street vacation remains a legislative decision of the City Council.
3. The proposal is categorically exempt from environmental review pursuant to WAC 197-11-800(2)(i).
4. The subject right-of-way is not required for current or reasonably foreseeable public use, subject to the retention of easements for utilities and public services.
5. The proposal is consistent with Chapter 35.79 RCW, the Port Angeles Municipal Code, and the Port Angeles Comprehensive Plan.
6. Approval of the street vacation does not authorize development. All future development remains subject to applicable permits and City standards.

### Recommended Conditions of Approval

After thorough review of Street Vacation Petition No. STV 26-0045, staff analysis indicates that the **following 7 conditions** are necessary to ensure compliance with Chapter 35.79 RCW and applicable City standards. These conditions are recommended to be placed on the approval to maintain consistency with the Port Angeles Municipal Code and adopted policy framework:

#### Valuation and Compensation

1. The petitioner shall provide a valuation of the subject property utilizing a professional appraisal service;
2. The applicant shall prepare and provide a quit claim deed or equivalent conveyance instrument acceptable to the City. The petitioner is responsible for recording the deed and all associated costs, fees, and implementation steps required to finalize the transfer of interest.
3. Prior to final City Council action, the petitioner shall provide a final legal description and exhibit map of the area to be vacated, subject to City review and approval.
4. Prior to filing conveyance with the Clallam County Auditor's Office, payment to the City of the full appraised value shall be made.

Exhibit 1: Staff Report |STV 26-0045 |Port of Port Angeles Street Vacation Petition

5. The petitioner shall be responsible for all recording fees, document preparation, and implementation steps required to finalize the vacation.
6. The final ordinance and associated conveyance documents shall be recorded with the Clallam County Auditor. The street vacation shall not take effect until such recording has occurred.

General Compliance

7. Approval of the street vacation does not waive compliance with any other applicable local, state, or federal regulations. All future development activities shall be subject to separate permit review and approval.

**VIII. EXHIBITS**

---

**Exhibit 2:** Application Materials

**Exhibit 3:** Notice of Complete Application

**Exhibit 4:** Public Comment Memo



# APPLICATION COVER SHEET

Department of Community & Economic Development

321 E. 5th Street, Port Angeles, WA 98362

360.417.4750 | [www.cityofpa.us](http://www.cityofpa.us) | [ced@cityofpa.us](mailto:ced@cityofpa.us)

## APPLICANT INFORMATION

Applicant Name: \_\_\_\_\_ (Property Owner:  Yes  No)

Mailing Address: \_\_\_\_\_

Phone: \_\_\_\_\_ Email: \_\_\_\_\_

Applicant's Representative (If other than applicant): \_\_\_\_\_

Phone: \_\_\_\_\_ Email: \_\_\_\_\_

## SUBJECT PROPERTY

Property Owner(s): \_\_\_\_\_

Property Owner Address: \_\_\_\_\_

Full Street Address: \_\_\_\_\_

Full Legal Description: \_\_\_\_\_

Parcel ID: \_\_\_\_\_

Current Zoning: \_\_\_\_\_

## APPLICATION / PERMIT TYPE

### ENVIRONMENTAL

- Environmental Sensitive Area
- Flood Development
- Shoreline Development
- State Environmental Policy Act
- Wetland Permit

### LAND DIVISION AND ALTERATION

- Annexation
- Boundary Line Adjustment
- Short Plat
- Subdivision
- Street Vacation

OTHER:  Lot Conformation

### MUNICIPAL

- Municipal Code Amendment
- Comprehensive Plan Amendment

### ZONING & USES

- Conditional Use - Type:
- Home Occupation
- Temporary Use
- Unclassified Use
- Overlay - Type:
- Variance - Type:
- Mobile & Itinerant Vendor – Type:
- Rezone

NOTE: PRE-application meeting waived per meeting of 2/12/26

### STAFF USE ONLY:

Notes:

Date Stamp



# STREET VACATION PETITION

Department of Community & Economic Development

321 E. 5th Street, Port Angeles, WA 98362

360.417.4750 | [www.cityofpa.us](http://www.cityofpa.us) | [ced@cityofpa.us](mailto:ced@cityofpa.us)

Any property owner(s) with land abutting a city-owned street/alley/place/cul-de-sac may petition the City Council for the vacation of all or part of the city-owned area.

Please mark all that apply:

- The area is owned by the City of Port Angeles.
- The area does NOT abut fresh or saltwater bodies.
- The area does NOT abut an Environmentally Sensitive Area (ESA)

(If any boxes remain unchecked, your petition may require additional procedures, studies, permits, or fees)

It is recommended that interested parties have a preliminary consultation meeting with City Staff. Interested parties pursuing a vacation should submit a completed Street Vacation Packet to the Department of Community and Economic Development in person, by mail, or by email.

## REQUIRED MATERIALS CHECKLIST

A completed petition packet will contain the following materials;

- Vicinity Map: A vicinity map identifying the general location of the vacation area relative to surrounding areas and land uses.
- Vacation Area Plan: A plan/map clearly defining the area that is to be petitioned for vacation, including measurements or survey, North arrow, scale, date, as well as identification of all properties and their owners abutting the vacation area.
- The assessed value of the property by the appraiser. See Note below.

The vacation process conforms with guidelines in [Title 35.79](#) in the Revised Code of Washington (RCW) Port Angeles Municipal Code Section 17.95.020 and 3.70.070 (P) specify zoning regulations and fees, respectively.

**Note:** The Port conducted an appraisal for industrial land in 2022 that valued Industrial land (near the airport) in Port Angeles at approximately \$3 per square foot. Assuming a 3% increase per year (10% approximately) the value is \$3.30- \$4.00 per square foot.

At 15,664 x \$3.30 the value is: \$51,691.20

At 15,664 x \$4.00 the value is: \$62,656

### STAFF USE ONLY:

Notes:

Date Stamp



# STREET VACATION PETITION

Department of Community & Economic Development

321 E. 5th Street, Port Angeles, WA 98362

360.417.4750 | [www.cityofpa.us](http://www.cityofpa.us) | [ced@cityofpa.us](mailto:ced@cityofpa.us)

To: The City Council of The City of Port Angeles

Subject:  Street Vacation  Alley Vacation  Place Vacation  Cul-de-sac Vacation Petition

We, the undersigned petitioners, request that the following described part of:

See attached.

in the City of Port Angeles be vacated pursuant to [RCW 35.79](#). The right-of-way is legally described as:

See attached.

There is (are) (one) owner(s) of property abutting said right-of-way. The undersigned petitioners are the owners of an interest in real estate abutting the above-described area. The undersigned petitioners constitute more than two thirds of the owners of said abutting property. Wherefore, the petitioners ask that proceedings be had hereon for the vacation of said area described above.

Respectfully signed,

PORT OF PORT ANGELES

**Petitioner:**

Address: 38 West First Street Port Angeles WA

Email: calebm@PORTOFPA.COM Phone: 360-457-8527

\_\_\_\_\_ *[Signature]* for the Port of Port Angeles  
Petitioner: \_\_\_\_\_  
Print Name Signature Date

Address: Candyn Lake Email: \_\_\_\_\_ Phone: \_\_\_\_\_

**Petitioner:** Print Name Signature Date

Address: \_\_\_\_\_ Email: \_\_\_\_\_ Phone: \_\_\_\_\_

LEGAL DESCRIPTION  
OF STREET VACATION PETITION

THE FOLLOWING PORTIONS OF LOTS 1 THROUGH 10, INCLUSIVE BLOCK 105 TOWNSITE OF PORT ANGELES: THOSE PORTION OF VACATED "B" AND "C" CONVEYED TO THE CITY OF PORT ANGELES FOR STREET PURPOSES BY DEED RECORDED DECEMBER 7, 1954 UNDER AUDITOR'S FILE NO. 284003.

SITUATE IN CLALLAM COUNTY, STATE OF WASHINGTON.

THE FOLLOWING PORTIONS OF LOTS 1 THROUGH 4, INCLUSIVE IN BLOCK 110, 105 TOWNSITE OF PORT ANGELES: THOSE PORTION OF VACATED "B" AND "C" CONVEYED TO THE CITY OF PORT ANGELES FOR STREET PURPOSES BY DEED RECORDED DECEMBER 7, 1954 UNDER AUDITOR'S FILE NO. 284003.

SITUATE IN CLALLAM COUNTY, STATE OF WASHINGTON.

# Vicinity Map

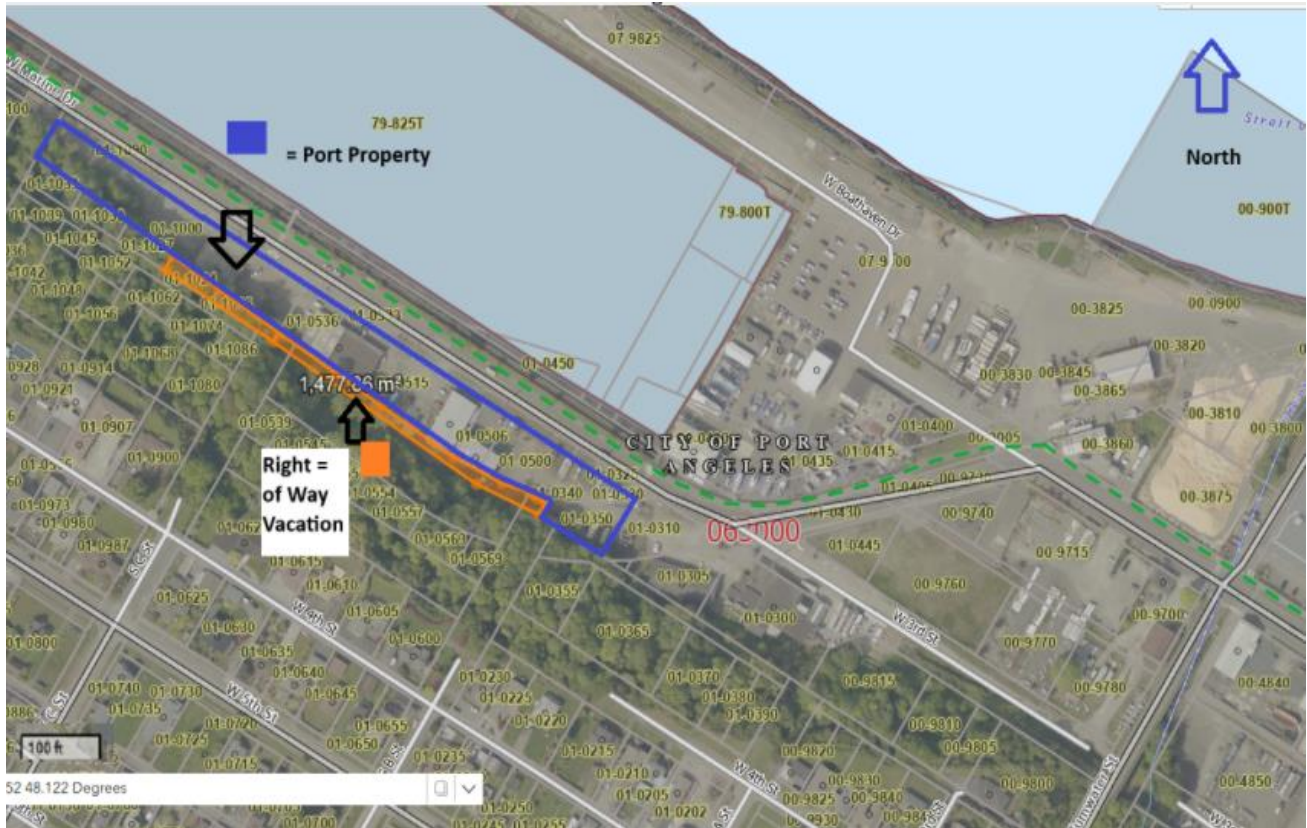

# Port of Port Angeles - Vacation Area Plan

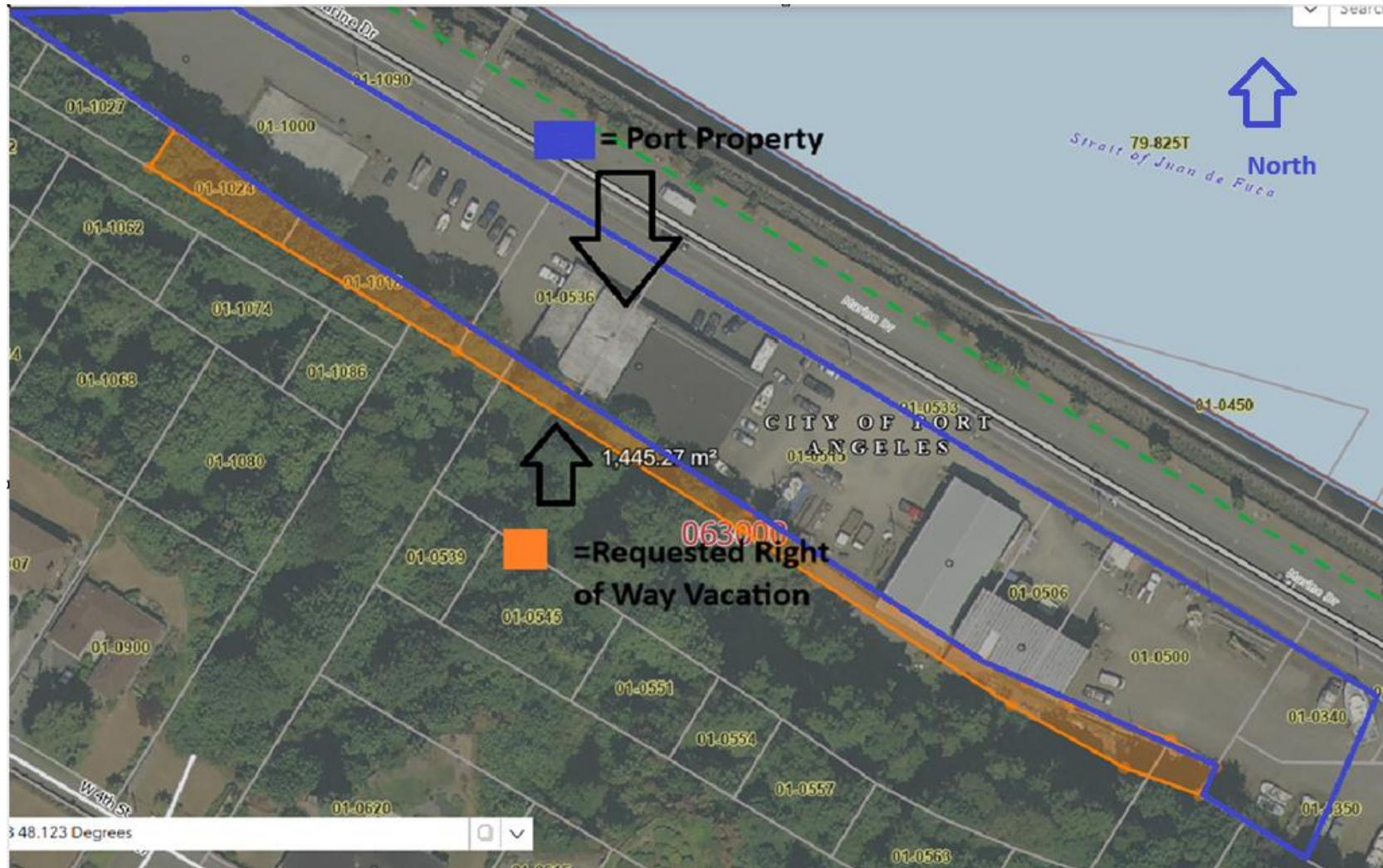

542052

# BEARING'S INC.

Building Location Site

## RECORD OF SURVEY BLOCK 110 to the Townsite of PORT ANGELES

# FOR

MARINE DRIVE

Scale: 1" = 20'

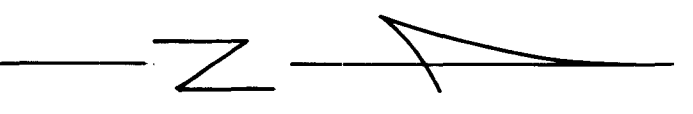

**BASIS of BEARINGS**  
This survey is based on a map which is on file at Port Angeles City Hall, Port Angeles, Washington.

**SURVEYOR'S CERTIFICATE**  
This map correctly represents a survey made by me or under my direction in conformance with the requirements of the Survey Recording Act.

*Donald H. Ferguson*  
Surveyor

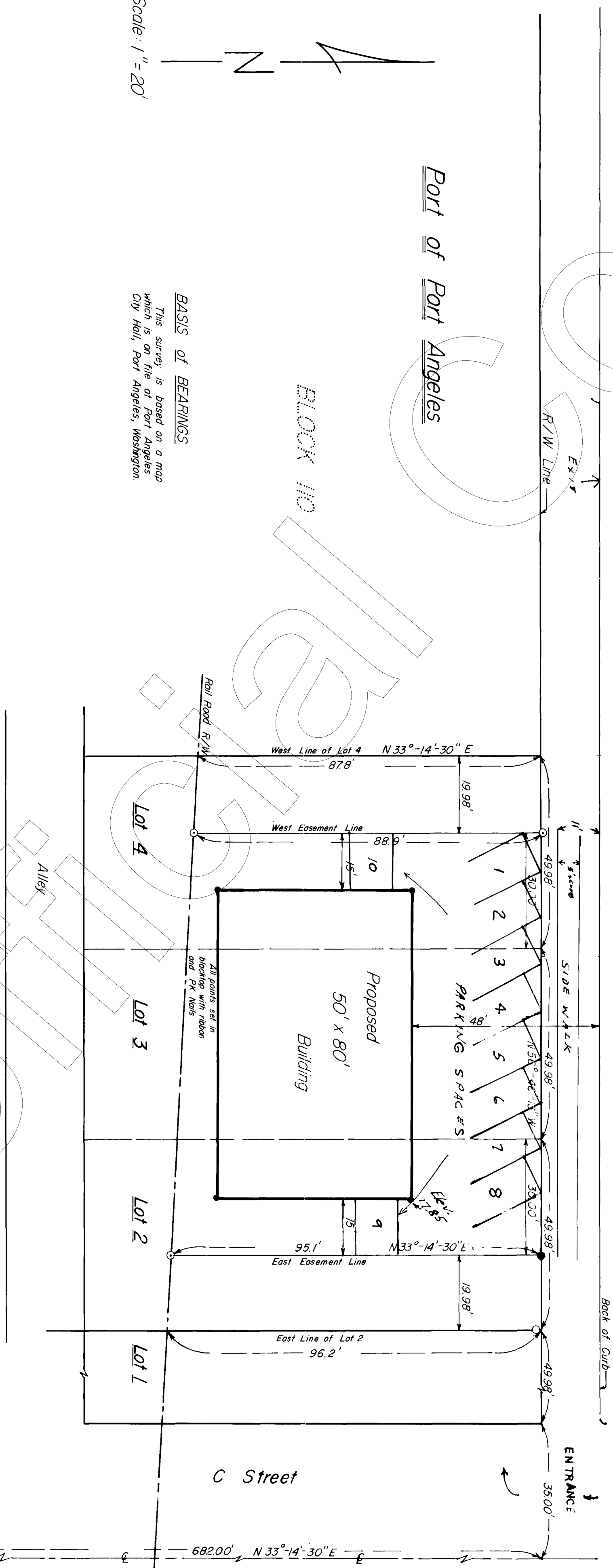

**LEGEND**  
○ Rebar & Cop  
● Pin-Nail

**FILING RECORD**  
Filed for record at the request of Earl Engineering  
this 19th day of August, 1983 A.D., at 11:00 minutes past 11 o'clock A.M. and recorded in Volume 9  
or surveys, at Page 26, Records of Clallam County, Washington.

MARY HOESLY  
County Auditor

Pauline Beaman  
Deputy

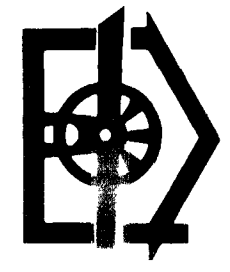

**ESTES REALTY,  
ENGINEERING &  
LAND SURVEYING, INC.**

PHONE (206) 457-8593  
1126 E. FRONT ST., PORT ANGELES, WA 98262

# RECORD OF SURVEY OF LEASE WITHIN LOTS 2, 3 AND 4 OF BLOCK 110, PORT ANGELES TOWNSITE, CLALLAM COUNTY, WASHINGTON

FOR: PORT OF PORT ANGELES

SHEET 1 OF 2

SEE SHEET 2 FOR NOTES AND BLOCK BREAKDOWN

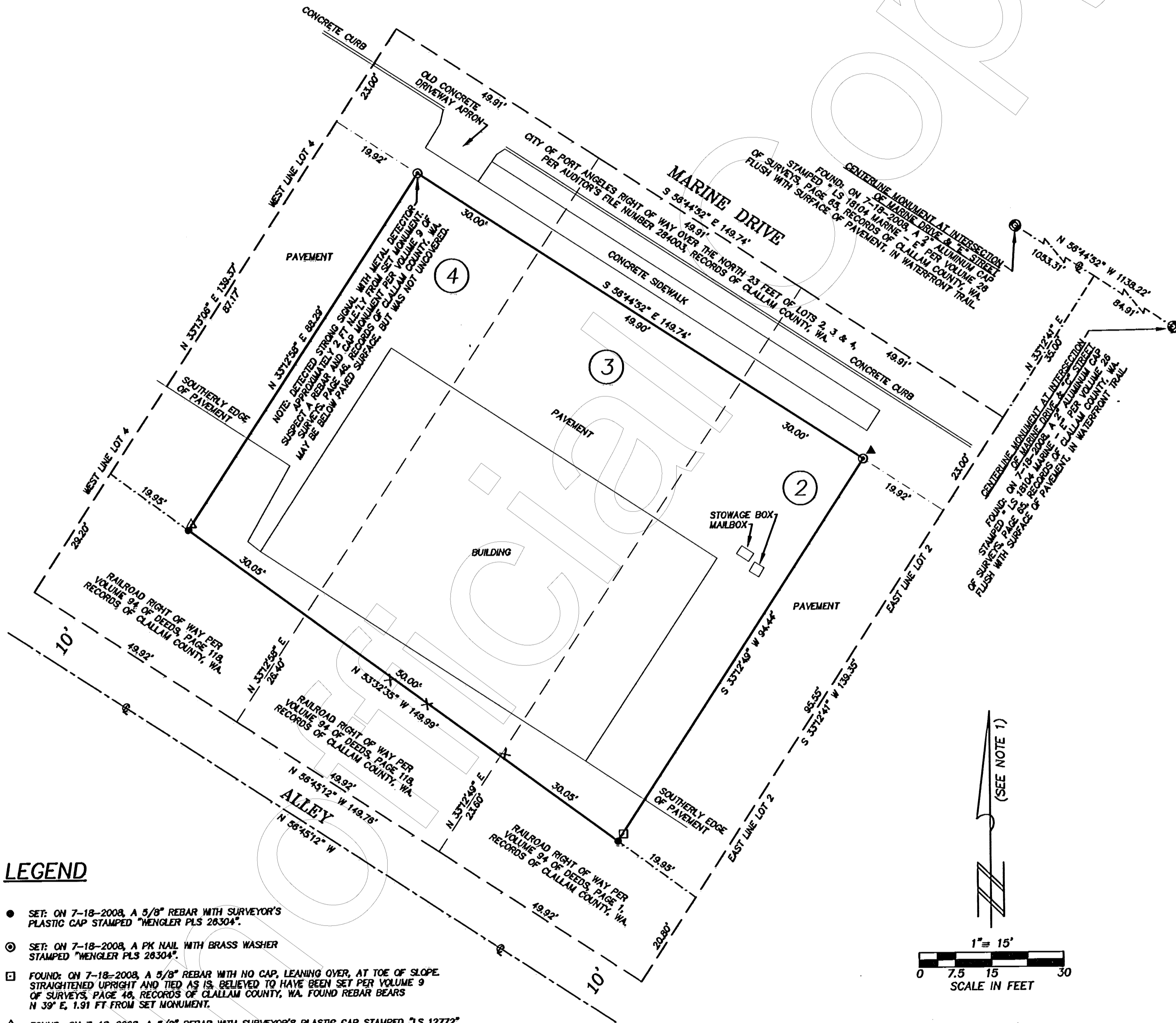

### LEGEND

- SET: ON 7-18-2008, A 5/8" REBAR WITH SURVEYOR'S PLASTIC CAP STAMPED "WENGLER PLS 26304".
- ⊙ SET: ON 7-18-2008, A PK NAIL WITH BRASS WASHER STAMPED "WENGLER PLS 26304".
- ⊠ FOUND: ON 7-18-2008, A 5/8" REBAR WITH NO CAP, LEANING OVER, AT TOE OF SLOPE, STRAIGHTENED UPRIGHT AND TIED AS IS, BELIEVED TO HAVE BEEN SET PER VOLUME 9 OF SURVEYS, PAGE 48, RECORDS OF CLALLAM COUNTY, WA. FOUND REBAR BEARS N 39° E, 1.91 FT FROM SET MONUMENT.
- △ FOUND: ON 7-18-2008, A 5/8" REBAR WITH SURVEYOR'S PLASTIC CAP STAMPED "LS 12772" PER VOLUME 9 OF SURVEYS, PAGE 48, RECORDS OF CLALLAM COUNTY, WA. FOUND REBAR AND CAP BEARS N 29° E, 1.34 FT FROM SET MONUMENT.
- ▲ FOUND: ON 7-18-2008, A PK NAIL IN PAVEMENT WITH OLD SURVEY FLAGGING UNDERNEATH, PER VOLUME 9 OF SURVEYS, PAGE 48, RECORDS OF CLALLAM COUNTY, WA. FOUND PK BEARS N 45° E, 2.30 FT FROM SET MONUMENT.
- × FOUND: ON 7-18-2008, 2" X 2" WOODEN STAKES APPROXIMATELY 5 FT TALL.

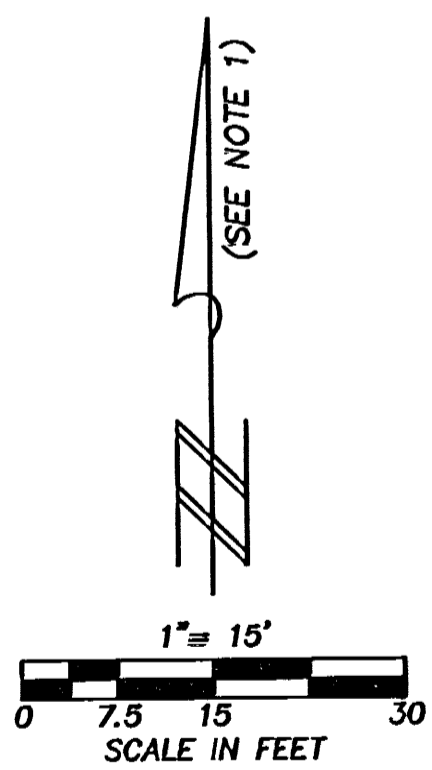

VOL 66 PG 97

### AUDITOR'S CERTIFICATE

FILED FOR RECORD THIS 15<sup>th</sup> DAY OF September, 2008  
AT 4:04 P.M. IN BOOK 66 OF SURVEYS AT PAGE 97  
AT THE REQUEST OF WENGLER SURVEYING AND MAPPING CO.

*Joni Elliott*  
DEPUTY COUNTY AUDITOR

AUDITOR'S FILE NUMBER 2008-1226671

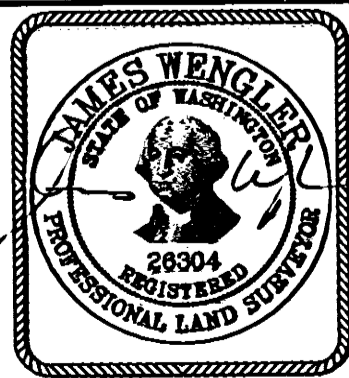

DATE: 9-15-2008

### SURVEYOR'S CERTIFICATE

THIS MAP CORRECTLY REPRESENTS A SURVEY MADE BY ME OR UNDER MY DIRECTION IN CONFORMANCE WITH THE REQUIREMENTS OF THE SURVEY RECORDING ACT AT THE REQUEST OF THE PORT OF PORT ANGELES IN JULY, 2008.

*James Wengler*  
JAMES WENGLER, P.L.S. 26304

### WENGLER SURVEYING & MAPPING CO.

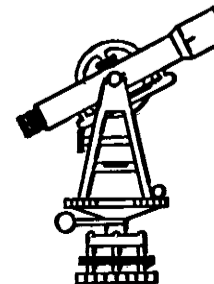

703 EAST EIGHTH STREET  
PORT ANGELES, WASHINGTON 98362  
(360) 457-9600  
FAX (360) 457-9556  
www.wenglersurveying.com

# RECORD OF SURVEY

## OF LEASE WITHIN LOTS 2, 3 AND 4 OF BLOCK 110, PORT ANGELES TOWNSITE, CLALLAM COUNTY, WASHINGTON

FOR: PORT OF PORT ANGELES

SHEET 2 OF 2  
BREAKDOWN OF BLOCK 110

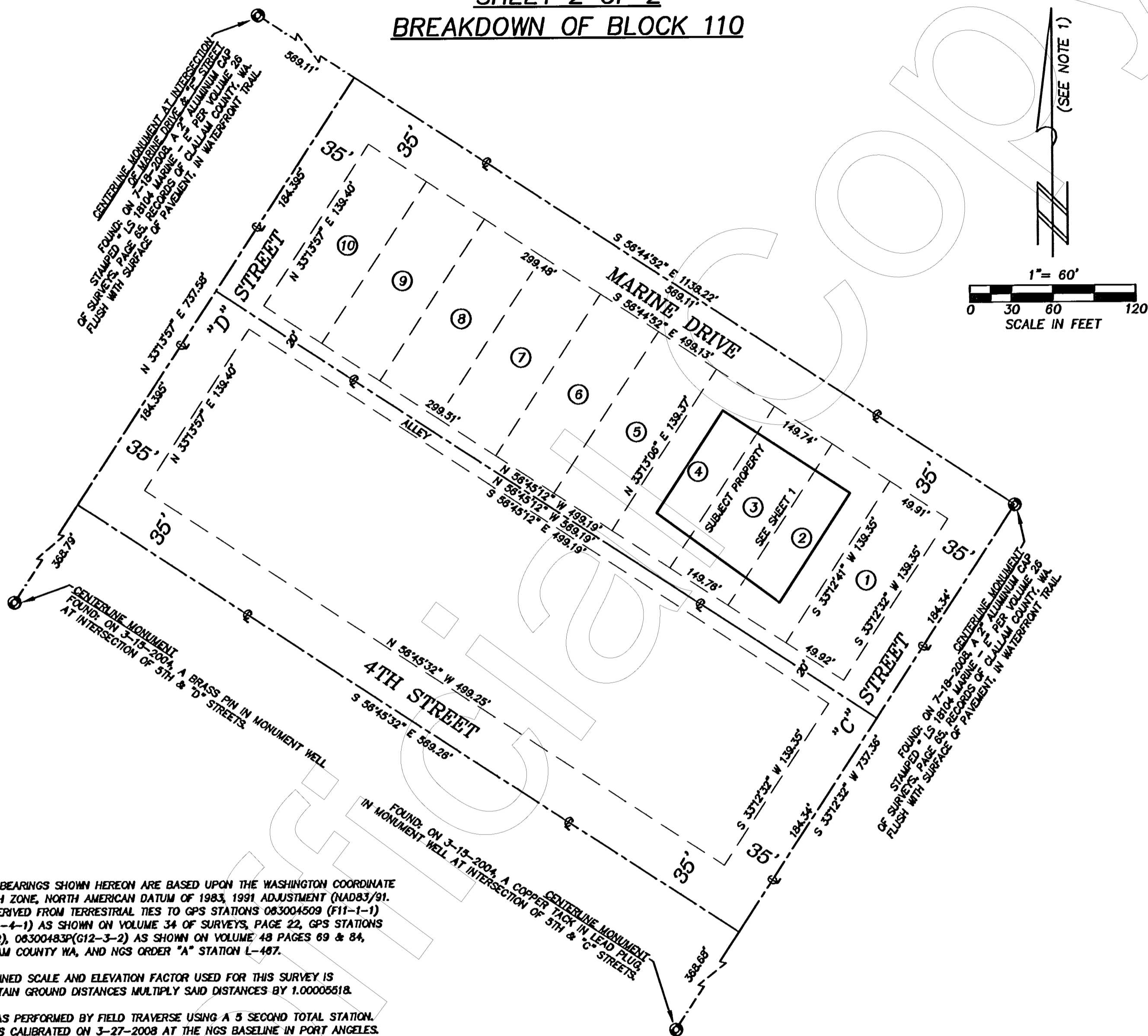

### NOTES

1.) DISTANCES AND BEARINGS SHOWN HEREON ARE BASED UPON THE WASHINGTON COORDINATE SYSTEM GRID, NORTH ZONE, NORTH AMERICAN DATUM OF 1983, 1991 ADJUSTMENT (NAD83/91). SAID DATUM WAS DERIVED FROM TERRESTRIAL TIES TO GPS STATIONS 083004509 (F11-1-1) AND 08300980P(H11-4-1) AS SHOWN ON VOLUME 34 OF SURVEYS, PAGE 22, GPS STATIONS 08300482P(G11-1-2), 08300483P(G12-3-2) AS SHOWN ON VOLUME 48 PAGES 69 & 84, RECORDS OF CLALLAM COUNTY WA, AND NGS ORDER "A" STATION L-487.

THE AVERAGE COMBINED SCALE AND ELEVATION FACTOR USED FOR THIS SURVEY IS 0.99994482. TO OBTAIN GROUND DISTANCES MULTIPLY SAID DISTANCES BY 1.00005518.

2.) THIS SURVEY WAS PERFORMED BY FIELD TRAVERSE USING A 5 SECOND TOTAL STATION. EDM EQUIPMENT WAS CALIBRATED ON 3-27-2008 AT THE NGS BASELINE IN PORT ANGELES.

3.) THIS SURVEY DOES NOT PURPORT TO SHOW THE EXISTENCE OF ALL EASEMENTS AND OR ENCUMBRANCES RECORDED OR UNRECORDED THAT MAY AFFECT THIS PROPERTY.

4.) THIS SURVEY IS BASED UPON THE G.L.O. PLAT OF THE TOWNSITE OF PORT ANGELES TOGETHER WITH VARIOUS MONUMENTATION PLANS ON FILE WITH THE CITY OF PORT ANGELES.

5.) FOR PROPERTY DESCRIPTION OF RECORD SEE AUDITOR'S FILE NUMBER 605411, RECORDS OF CLALLAM COUNTY, WASHINGTON.

6.) PROCEDURE USED FOR THE SUBDIVISION OF BLOCK 110 IS AS FOLLOWS:

THE INTERSECTION OF 4TH & "C" STREETS WAS CALCULATED AT A MIDPOINT BETWEEN THE FOUND MONUMENTS AT THE INTERSECTION OF MARINE DRIVE & "C" STREET AND THE INTERSECTION OF 5TH & "C" STREETS.

THE INTERSECTION OF 4TH & "D" STREETS WAS CALCULATED AT A MIDPOINT BETWEEN FOUND MONUMENTS AT THE INTERSECTION OF MARINE DRIVE & "D" STREET AND THE INTERSECTION OF 5TH & "D" STREETS

THE INTERSECTION OF MARINE DRIVE & "D" STREET WAS CALCULATED AT A MIDPOINT BETWEEN FOUND MONUMENTS AT THE INTERSECTION OF MARINE DRIVE & "E" STREET AND THE INTERSECTION OF MARINE DRIVE & "C" STREET.

7.) AN ALTERNATE SOLUTION WAS EVALUATED USING THE MONUMENTS ALONG "C" AND "D" STREETS AND MONUMENTS FOUND ALONG 4TH STREET AT THE INTERSECTIONS WITH "A" AND "K" STREETS TO CALCULATE THE INTERSECTIONS ALONG 4TH STREET AT "C" AND "D" STREETS.

THE POSITIONS CALCULATED PER THIS ALTERNATE SOLUTION FALL WITHIN SEVERAL HUNDREDTHS OF A FOOT HORIZONTALLY OF THOSE POSITIONS DERIVED FROM THE METHOD DESCRIBED IN NOTE 6. THIS DIFFERENCE WAS CONSIDERED NEGLIGIBLE AND THE SOLUTION AS DESCRIBED IN NOTE 6 WAS HELD.

8.) A PREVIOUS SURVEY OF THIS LEASE LOT WAS PERFORMED IN 1983 BY DONALD P. HIGGINS, PLS, RECORDED UNDER VOLUME 9, PAGE 46, RECORDS OF CLALLAM COUNTY, WASHINGTON. SAID SURVEY WAS FOUND TO BE SIGNIFICANTLY LACKING IN BASIC SURVEY INFORMATION. MR. HIGGINS DOES NOT DISCLOSE ANY CONTROLLING CENTERLINE MONUMENTATION INFORMATION, OR WHAT METHOD WAS USED TO LOCATE THE CENTERLINES, RIGHT OF WAY LINES AND LOT LINES AS REPRESENTED THEREON. MR. HIGGINS'S MONUMENTS WERE FOUND TO BE BETWEEN 1.34 FT AND 2.30 FT NORTHEASTERLY FROM OUR CALCULATED POSITIONS FOR THE LOT CORNERS THEY WERE INTENDED TO REPRESENT AND WERE REJECTED.

9.) THIS SURVEY WAS PERFORMED ACCORDING TO WAC 332-130-090 STANDARDS FOR LAND BOUNDARY SURVEYS. THIS SURVEY WAS NOT PERFORMED OR CERTIFIED TO MEET THE "MINIMUM STANDARD DETAIL REQUIREMENTS" OR "ACCURACY STANDARDS" FOR ALTA/ACSM LAND TITLE SURVEYS. THEREFORE, THE USE OF THIS MAP FOR THE ISSUANCE OF AN ALTA/ACSM OWNER'S EXTENDED COVERAGE POLICY IS STRICTLY PROHIBITED.

### AUDITOR'S CERTIFICATE

FILED FOR RECORD THIS 15<sup>th</sup> DAY OF September, 2008  
AT 4:04 P.M. IN BOOK 666 OF SURVEYS AT PAGE 97  
AT THE REQUEST OF WENGLER SURVEYING AND MAPPING CO.

Joni Elliott  
DEPUTY COUNTY AUDITOR

AUDITOR'S FILE NUMBER 2008-1226671

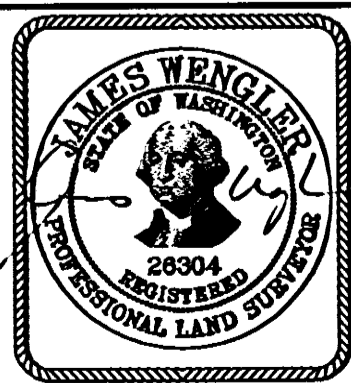

DATE: 9-15-2008

### SURVEYOR'S CERTIFICATE

THIS MAP CORRECTLY REPRESENTS A SURVEY MADE BY ME OR UNDER MY DIRECTION IN CONFORMANCE WITH THE REQUIREMENTS OF THE SURVEY RECORDING ACT AT THE REQUEST OF THE PORT OF PORT ANGELES IN JULY, 2008.

James Wengler  
JAMES WENGLER, P.L.S. 26304

### WENGLER SURVEYING & MAPPING CO.

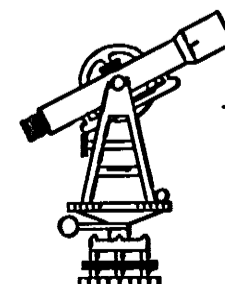

703 EAST EIGHTH STREET  
PORT ANGELES, WASHINGTON 98362

(360) 457-9800

FAX (360) 457-9556

www.wenglersurveying.com

VOL 66 PG 97

2017-1350094 Y. 88 P. 047  
 Zenovic & Associates  
 Clallam County Washington 05/30/2017 08:48:49 AM

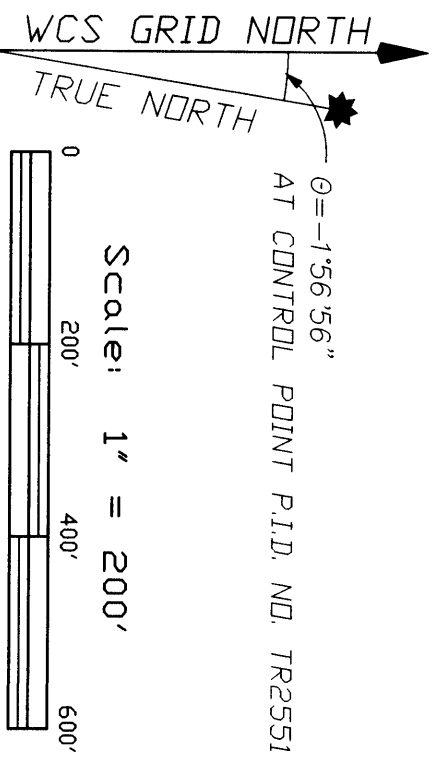

Scale: 1" = 200'  
 SECTION INDEX:  
 BLOCK 103, 105 AND 110  
 T.P.A.

- NOTES:
- THE PURPOSE OF THIS SURVEY WAS TO MONUMENT THE SOUTHERLY LIMITS OF THE PARCELS DESCRIBED HEREON.
- THE PROCEDURES USED FOR THE SUBDIVISION OF BLOCKS 103, 105 AND 110 ARE AS FOLLOWS:
- THE INTERSECTION OF MARINE DRIVE AND D STREET WAS CALCULATED AT THE MIDPOINT BETWEEN THE FOUND MONUMENTS AT THE INTERSECTION OF MARINE & E STREET AND THE INTERSECTION OF MARINE & C STREET.
- THE INTERSECTION OF 4TH & D STREET WAS CALCULATED AT THE MIDPOINT BETWEEN THE CALCULATED INTERSECTION OF MARINE & D STREET AND THE FOUND MONUMENT AT THE INTERSECTION OF 5TH & D STREET.
- THE INTERSECTION OF 4TH & C STREET WAS CALCULATED AT THE MIDPOINT BETWEEN THE FOUND MONUMENTS AT THE INTERSECTION OF MARINE & C STREET AND THE INTERSECTION OF 5TH & C STREET.
- THE INTERSECTION OF 3RD & A STREET WAS CALCULATED AT G.L.O. DISTANCE ON A BEARING EXTENDED FROM THE FOUND MONUMENTS AT THE INTERSECTION OF 8TH & A STREET AND THE INTERSECTION OF 4TH & A STREET.
- THE INTERSECTION OF MARINE DRIVE & B STREET WAS CALCULATED AT THE MIDPOINT BETWEEN THE CALCULATED POSITION OF THE INTERSECTION OF 3RD & A STREET AND THE FOUND MONUMENT AT THE INTERSECTION OF MARINE DRIVE & C STREET.
- THE INTERSECTION OF 4TH & B STREET WAS CALCULATED AT THE MIDPOINT BETWEEN THE FOUND MONUMENT AT THE INTERSECTION OF 5TH & B STREET AND THE CALCULATED INTERSECTION OF MARINE DRIVE & B STREET.
- THIS SURVEY IS BASED ON THE G.L.O. PLAT OF THE TOWNSITE OF PORT ANGELES, WASHINGTON, TOGETHER WITH VARIOUS MONUMENTATION PLANS ON FILE AT THE CITY OF PORT ANGELES AND THIS OFFICE.
- FOR ADDITIONAL PERTINENT RECORDS OF SURVEY, SEE VOLUME 19 OF SURVEYS, PAGE 38, VOLUME 26 OF SURVEYS, PAGE 83, VOLUME 32 OF SURVEYS, PAGE 78, VOLUME 56 OF SURVEYS, PAGE 91 AND VOLUME 66 OF SURVEYS, PAGE 97.
- THE SOUTHERLY LIMITS OF THE FORMER RAILROAD RIGHT OF WAY WERE NOT DETERMINED PER THIS SURVEY.
- THIS SURVEY DOES NOT PURPORT TO SHOW ALL EASEMENTS AND/OR ENCUMBRANCES EITHER RECORDED OR UNRECORDED WHICH MAY AFFECT THE SURVEYED PARCELS.
- ALL DOCUMENTS CITED HEREON ARE RECORDS OF CLALLAM COUNTY, WASHINGTON.

FOUND 2" ALUMINUM CAP STAMPED MARINE-C, LS 18704 PER VOL. 28 OF SURVEYS, PG. 65 (12-2016)  
 FOUND BRASS PIN IN MONUMENT WELL AT INTERSECTION OF 5TH AND E STREETS (12-2005)  
 FOUND BRASS PIN IN MONUMENT WELL AT INTERSECTION OF 5TH AND D STREETS (12-2005)  
 FOUND BRASS PIN IN MONUMENT WELL AT INTERSECTION OF 5TH AND C STREETS (12-2005)  
 FOUND TACK IN LEAD PLUG IN MONUMENT WELL AT INTERSECTION OF 5TH AND C STREETS (11-2004)  
 FOUND TACK IN LEAD PLUG IN MONUMENT WELL AT INTERSECTION OF 5TH AND B STREETS (2-2012)  
 FOUND BRASS PIN IN MONUMENT WELL AT INTERSECTION OF 4TH AND A STREETS (2-2012)  
 FOUND 2" ALUMINUM CAP STAMPED MARINE-C, LS 18704 PER VOL. 28 OF SURVEYS, PG. 65 (12-2016)  
 FOUND 2" ALUMINUM CAP PER VOL. 29 OF SURVEYS, PAGE 65 (3-2012)  
 FOUND 2" BRASS CAP PER VOL. 48 OF SURVEYS, PAGE 69 (2-2004)

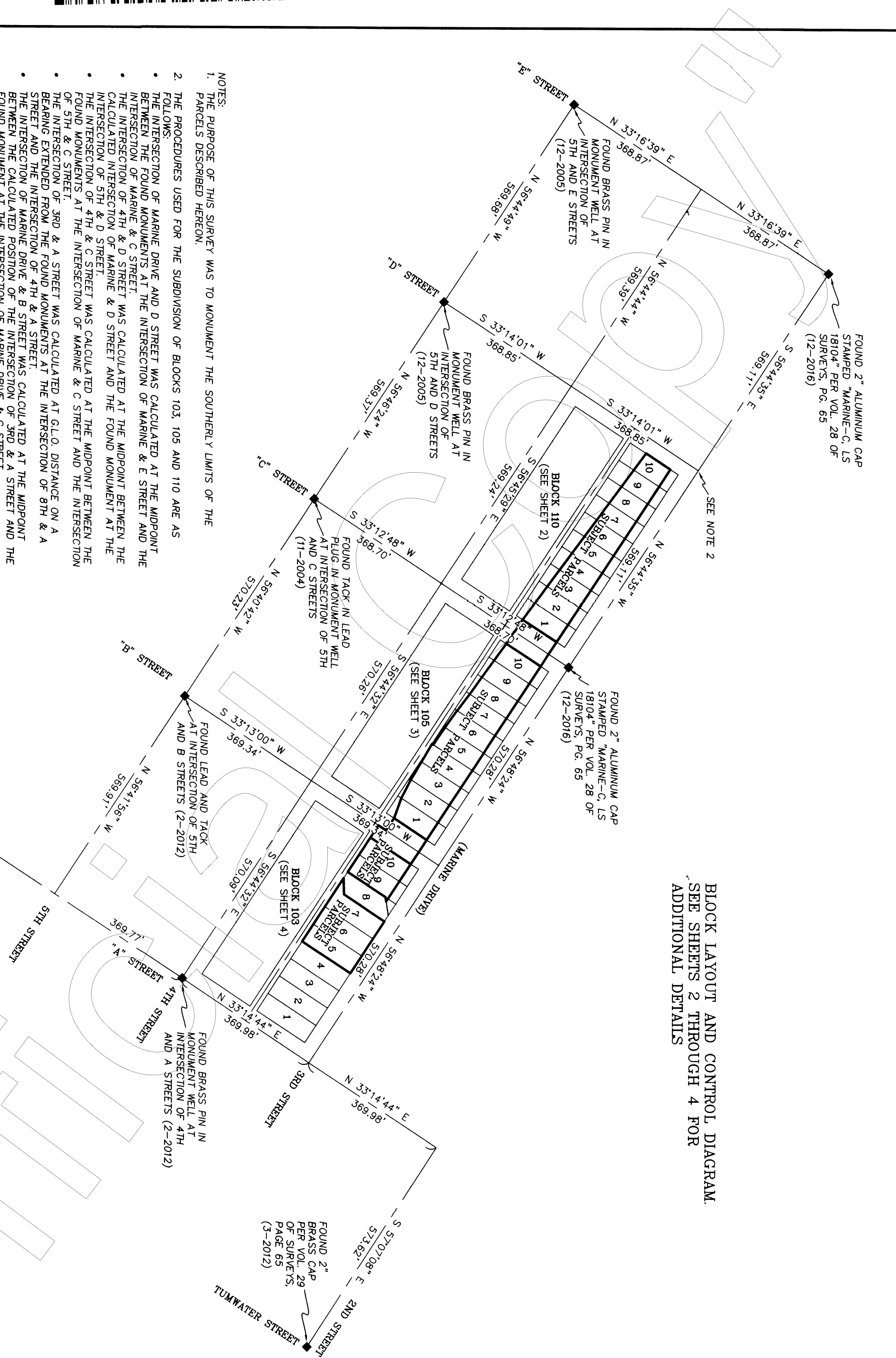

BLOCK LAYOUT AND CONTROL DIAGRAM.  
 SEE SHEETS 2 THROUGH 4 FOR ADDITIONAL DETAILS

# RECORD OF SURVEY

A PORTION OF BLOCKS 103, 105 AND 110  
 PORT ANGELES TOWNSITE  
 CLALLAM COUNTY, WASHINGTON  
 PREPARED FOR  
 PORT OF PORT ANGELES

LEGAL DESCRIPTION:

LOTS 5 THROUGH 10, INCLUSIVE, IN BLOCK 103; LOTS 1 THROUGH 10, INCLUSIVE, IN BLOCK 105; AND LOTS 1 THROUGH 10, INCLUSIVE, IN BLOCK 110; ALL IN THE TOWNSITE OF PORT ANGELES, CLALLAM COUNTY, WASHINGTON;

TOGETHER WITH THAT PORTION OF VACATED "B" STREET LYING BETWEEN BLOCKS 103 AND 105 AND THAT PORTION OF VACATED "C" STREET LYING BETWEEN BLOCKS 105 AND 110;

EXCEPT THOSE PORTIONS LYING WITHIN THE FORMER RIGHT OF WAY OF THE SEATTLE, PORT ANGELES AND LAKE CRESCENT RAILWAY;

ALSO EXCEPT THE NORTH 23 FEET OF LOTS 8, 9, AND 10 IN BLOCK 103; THE NORTH 23 FEET OF LOTS 1 THROUGH 10, INCLUSIVE, BLOCK 105 AND THE NORTH 23 FEET OF LOTS 1 THROUGH 10, INCLUSIVE, BLOCK 110; INCLUDING THE NORTH 23 FEET OF THOSE PORTIONS OF VACATED "B" AND "C" STREETS CONVEYED TO THE CITY OF PORT ANGELES FOR STREET PURPOSES BY DEED RECORDED DECEMBER 7, 1984 UNDER AUDITOR'S FILE NUMBER 284003;

TOGETHER WITH THOSE PORTIONS OF THE CHICAGO, MILWAUKEE, ST. PAUL AND PACIFIC RAILROAD RIGHT OF WAY OVER AND ACROSS LOTS 5, 6, 7, 9, AND 10 IN SAID BLOCK 103 ACQUIRED BY THE PORT OF PORT ANGELES IN JUDGEMENT QUIETING TITLE FILED NOVEMBER 17, 1987 IN CLALLAM COUNTY SUPERIOR COURT CAUSE NO. 87-2-00297-0.

SITUATE IN CLALLAM COUNTY, STATE OF WASHINGTON.  
 THE ABOVE DESCRIPTION DESCRIBES THE PARCEL(S) IDENTIFIED IN THE LIMITED LIABILITY CERTIFICATE #112779 ISSUED BY CLALLAM TITLE COMPANY OF PORT ANGELES, WASHINGTON.

PROCEDURES:  
 THIS RECORD OF SURVEY IS BASED ON A GROUND SURVEY UTILIZING CONVENTIONAL TRAVERSE METHODS.

THIS SURVEY MEETS OR EXCEEDS THE STANDARDS CONTAINED IN WAC 332-130-090.

EQUIPMENT:  
 TRIMBLE S-6 ROBOTIC 3" TOTAL STATION

DATE OF SURVEY:  
 DECEMBER THROUGH FEBRUARY, 2017

BASIS OF BEARINGS:  
 WASHINGTON STATE COORDINATE SYSTEM GRID, NORTH ZONE, (NAD 83/97), AS DETERMINED FROM FIELD MEASUREMENTS MADE TO CLALLAM COUNTY GEOMETRIC CONTROL MONUMENTS CP063004609 (711-1-1), CP063004829 (711-4-1) AS SHOWN ON VOLUME 34 OF SURVEYS, PAGE 22.  
 DISTANCES SHOWN HEREON ARE REDUCED TO SAID GRID BY A COMBINED SCALE FACTOR OF 0.99994426.

AUDITOR'S CERTIFICATE:

FILED FOR RECORD THIS 30<sup>th</sup> DAY OF May 2017,  
 AT 8:48AM, IN BOOK 80 OF SURVEYS, AT PAGE 47  
 AT THE REQUEST OF ZENOVIC & ASSOCIATES, INC.

*Doni Gumb* - Deputy Auditor's File Number: 2017-1350094  
 COUNTY AUDITOR



*John C. Ward*  
 JOHN C. WARD, PLS 48767  
 DATE: 5-18-2017

**ZENOVIC & ASSOCIATES**  
 INCORPORATED  
 301 E. SIXTH ST., STE. 1  
 PORT ANGELES, WA 98362  
 PHONE: (360) 417-0501  
 FAX: (360) 417-0514  
 SHEET 1 OF 4  
 DATE: 5/18/2017 JOB# 16411

**RECORD OF SURVEY**  
A PORTION OF BLOCKS 103, 105 AND 110  
PORT ANGELES TOWNSITE  
CLALLAM COUNTY, WASHINGTON  
PREPARED FOR  
PORT OF PORT ANGELES

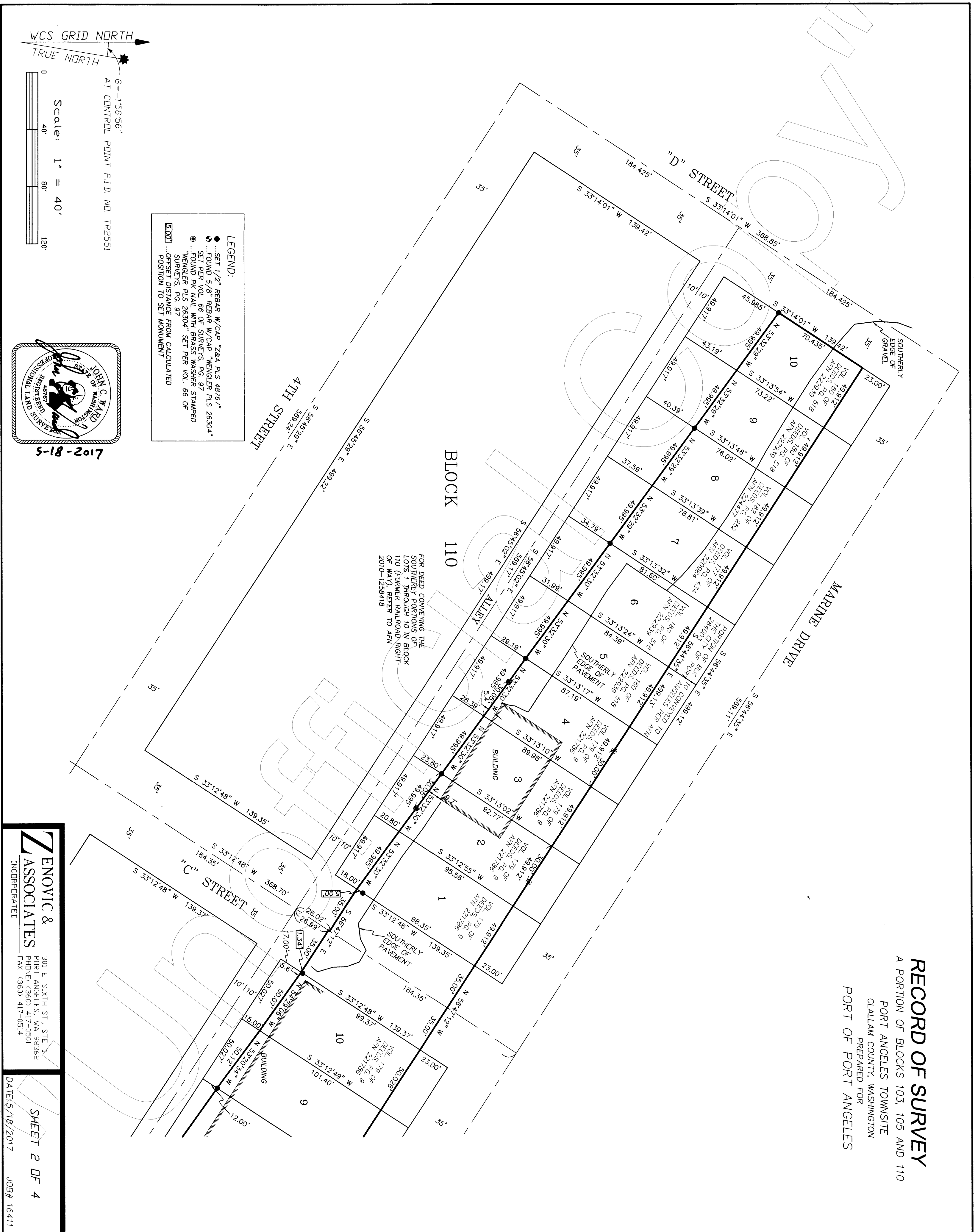

**LEGEND:**  
 ●...SET 1/2" REBAR W/CAP "Z&A PLUS 48767"  
 ○...FOUND 5/8" REBAR W/CAP "WENGLER PLUS 26304"  
 ○...SET PER VOL. 66 OF SURVEYS, PG. 97  
 ○...FOUND PK NAIL WITH BRASS WASHER STAMPED "WENGLER PLUS 26304" SET PER VOL. 66 OF SURVEYS, PG. 97  
 [500] ...OFFSET DISTANCE FROM CALCULATED POSITION TO SET MONUMENT

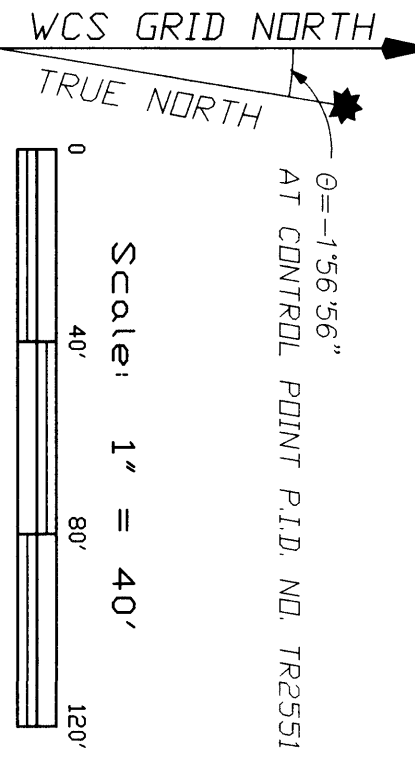

FOR DEED CONVERTING THE SOUTHERLY PORTIONS OF LOTS 1 THROUGH 10 IN BLOCK 110 (FORMER RAILROAD RIGHT OF WAY) REFER TO APN 2010-1258418

**ZENOVIC & ASSOCIATES**  
INCORPORATED

301 E. SIXTH ST., STE. 1  
PORT ANGELES, WA 98362  
PHONE: (360) 417-0501  
FAX: (360) 417-0514

DATE: 5/18/2017

SHEET 2 OF 4

VOL 80 PG 47

JOB# 16411

# RECORD OF SURVEY

A PORTION OF BLOCKS 103, 105 AND 110  
PORT ANGELES TOWNSITE  
CLALLAM COUNTY, WASHINGTON  
PREPARED FOR  
PORT OF PORT ANGELES

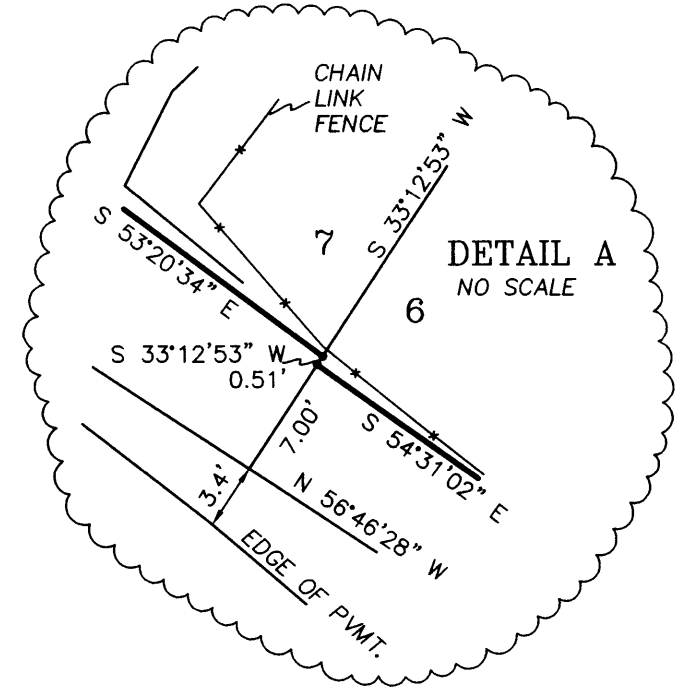
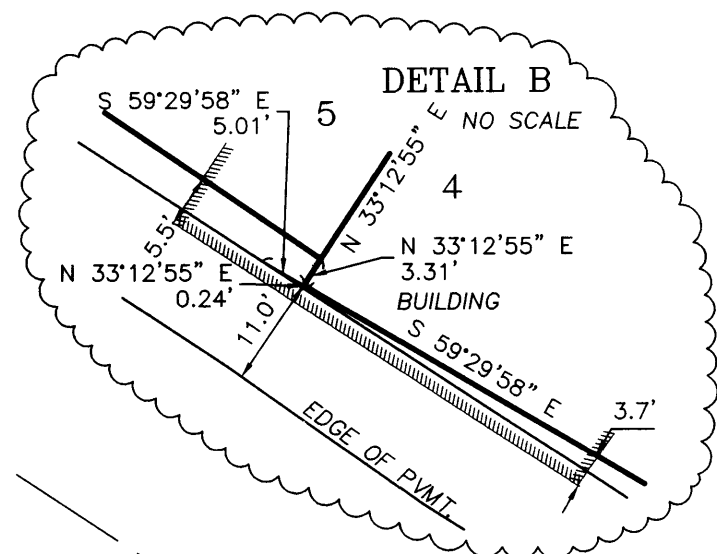
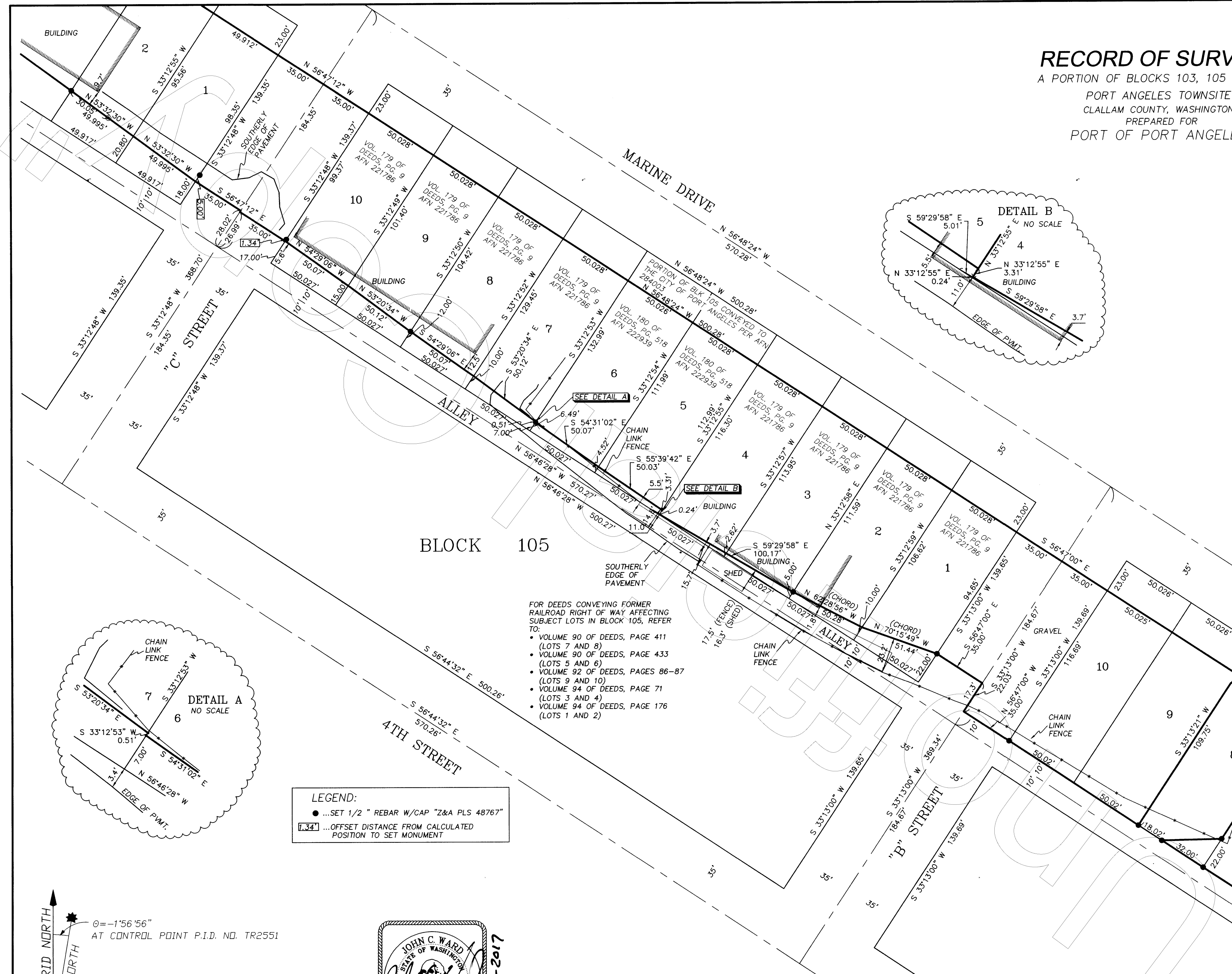

FOR DEEDS CONVEYING FORMER RAILROAD RIGHT OF WAY AFFECTING SUBJECT LOTS IN BLOCK 105, REFER TO:

- VOLUME 90 OF DEEDS, PAGE 411 (LOTS 7 AND 8)
- VOLUME 90 OF DEEDS, PAGE 433 (LOTS 5 AND 6)
- VOLUME 92 OF DEEDS, PAGES 86-87 (LOTS 9 AND 10)
- VOLUME 94 OF DEEDS, PAGE 71 (LOTS 3 AND 4)
- VOLUME 94 OF DEEDS, PAGE 176 (LOTS 1 AND 2)

LEGEND:  
● ...SET 1/2" REBAR W/CAP "Z&A PLS 48767"  
1.34' ...OFFSET DISTANCE FROM CALCULATED POSITION TO SET MONUMENT

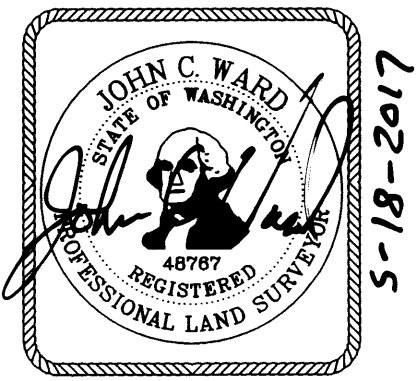
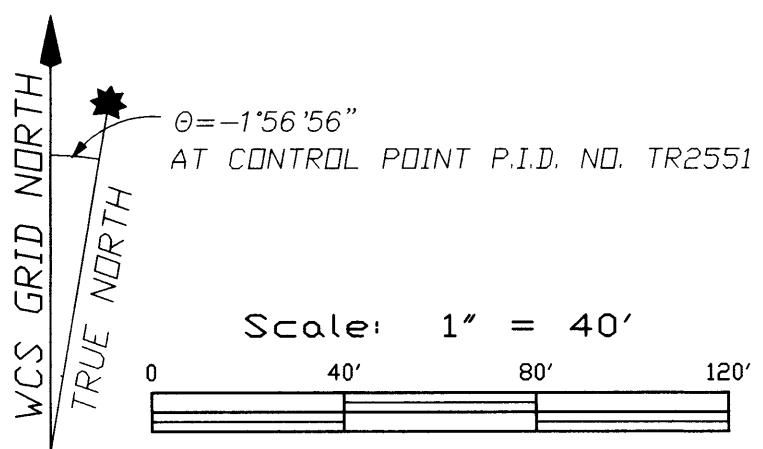

**ZENOVIC & ASSOCIATES** INCORPORATED  
301 E. SIXTH ST., STE. 1  
PORT ANGELES, WA 98362  
PHONE: (360) 417-0501  
FAX: (360) 417-0514

**SHEET 3 OF 4**  
DATE: 5/18/2017 JOB# 16411

2017-1350094 05/30/2017 08:48:49 AM 3 of 4 Clallam County, WASURVY ZENOVIC & ASSOCIATES

# RECORD OF SURVEY

A PORTION OF BLOCKS 103, 105 AND 110  
PORT ANGELES TOWNSITE  
CLALLAM COUNTY, WASHINGTON  
PREPARED FOR  
PORT OF PORT ANGELES

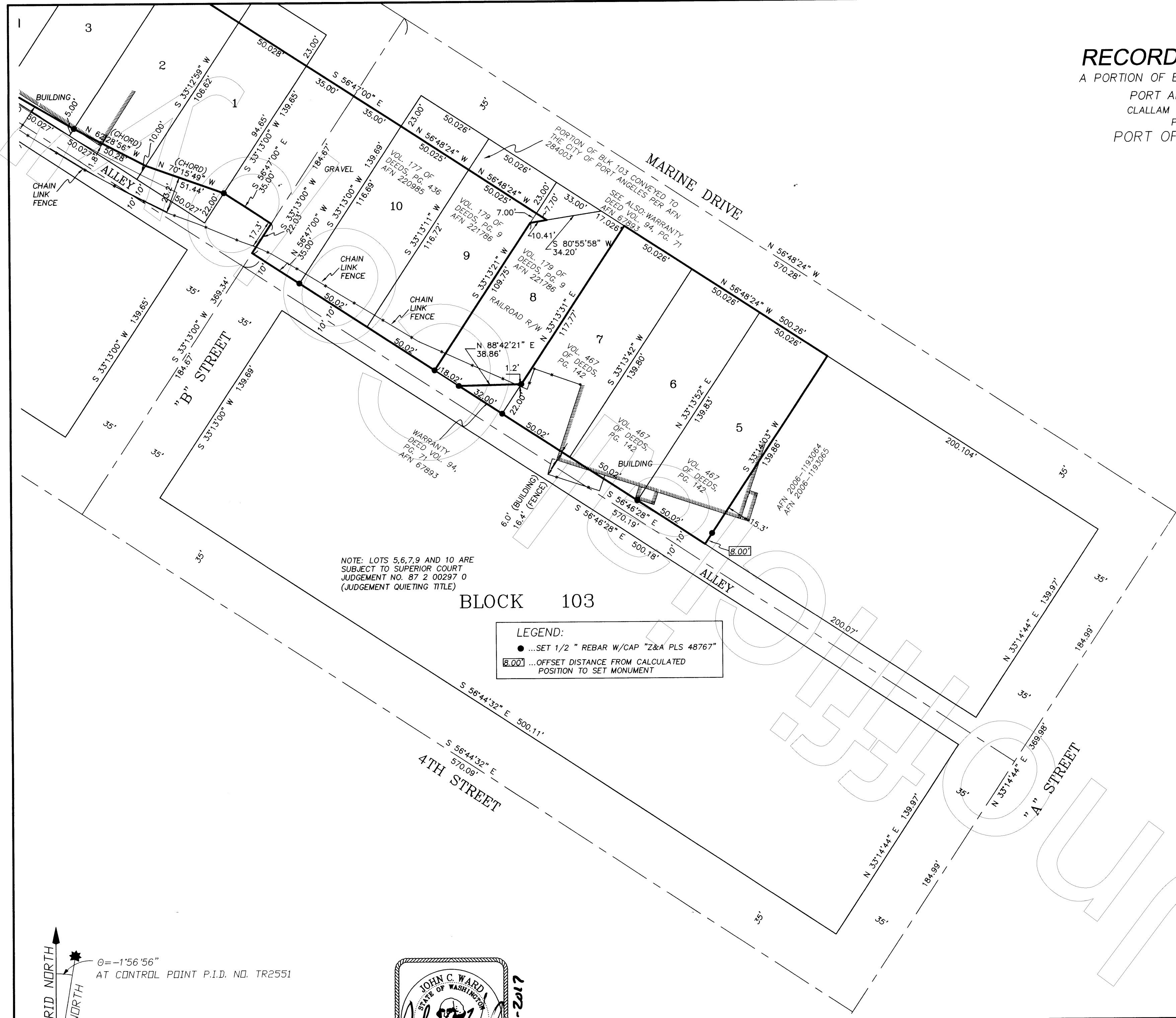

NOTE: LOTS 5, 6, 7, 9 AND 10 ARE SUBJECT TO SUPERIOR COURT JUDGEMENT NO. 87 2 00297 0 (JUDGEMENT QUIETING TITLE)

## BLOCK 103

**LEGEND:**

- ...SET 1/2" REBAR W/CAP "Z&A PLS 48767"
- 8.00 ...OFFSET DISTANCE FROM CALCULATED POSITION TO SET MONUMENT

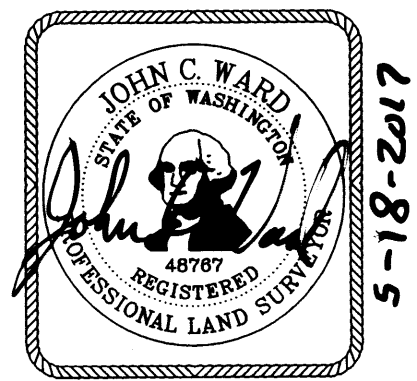
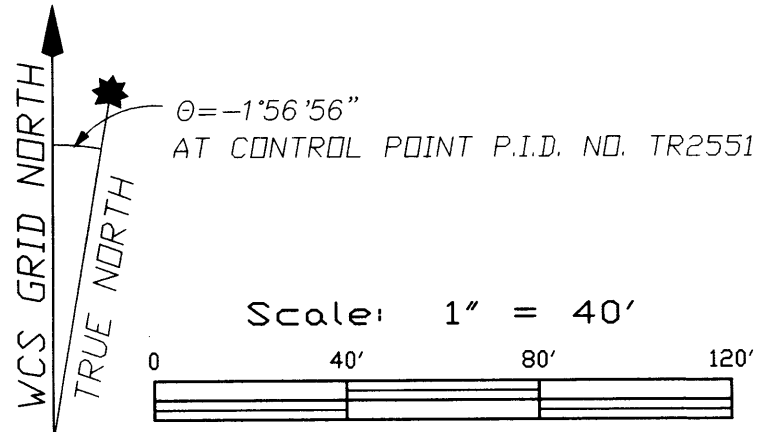

<p><b>ZENOVIC &amp; ASSOCIATES</b> INCORPORATED</p>	<p>301 E. SIXTH ST., STE. 1 PORT ANGELES, WA 98362 PHONE: (360) 417-0501 FAX: (360) 417-0514</p>	<p>SHEET 4 OF 4</p>
	<p>DATE: 5/18/2017</p>	<p>JOB# 16411</p>

2017-1350094 05/30/2017 08:48:49 AM 4 of 4 Clallam County, WASURVY ZENOVIC & ASSOCIATES



---

## MEMORANDUM

---

**DATE:** Friday, April 03, 2026  
**TO:** Hearing Examiner  
**FROM:** Angel Torres, *Long Range & Special Projects Administrator*  
**RE:** STV 26-0045 Public Comment

---

### INTRODUCTION

This memo and its attachment serves as the official response to public comment from City staff and includes all noticing procedures, documentation, individual comments as responses.

### PUBLIC NOTICING PROCEDURES

Public notice for Land Use Application STV 26-0045 was opened on Thursday, March 19, 2026, closed on Thursday, April 2, 2026, and was provided in the following manner

- In the Peninsula Daily News: March 19, 2026
- Onsite: March 19, 2026
- To all property owners within 300' of the exterior property boundaries of the proposal lot/s listed by the Clallam County Assessor: March 19, 2026
- At the City Hall Noticing Board: March 19, 2026
- On the City's Website: March 19, 2026

See Attachment A for noticing documentation.

### PUBLIC COMMENT

There was 1 individual public comment received by staff during the open public comment period.

Generally, the submitted comment expresses concern regarding potential stormwater and runoff impacts, bluff and soil stability, and noise and air emissions associated with the proposed right-of-way grant and Brix Marine project. The commenter requests thorough review and mitigation of these issues and states an intent to preserve legal remedies in the event of project-related harm.

### STAFF RESPONSE

the concerns regarding geologic hazard and related site stability are addressed through Environmentally Sensitive Areas Development Permit ESA 25-0177, as referenced in Condition 2 of Shoreline Substantial Development Permit SMA 25-0175, issued March 20, 2026. The shoreline decision states the project lies adjacent to a Geologically Hazardous Area and must comply with PAMC Chapter 15.20 and the conditions of ESA 25-0177.

Conditions placed on the permit in response to public comment

- N/A

Application No. 17-35 | UUP No. 11-15 Extension | 2917 Edgewood Drive

**Attachment A:** Public Noticing Documentation

**Attachment B:** Public Comment Response Matrix

**Attachment C:** Individual Written Comments by Date Received