

## CHAPTER 8 – ELECTRIC UTILITY

### "URBAN SERVICES STANDARDS AND GUIDELINES"

CITY OF PORT ANGELES – PUBLIC WORKS & UTILITIES DEPARTMENT

#### 8.01 GENERAL CONSIDERATIONS

- A. This document was prepared to aid in establishing electric service for new and remodeled structures. Specific regulations governing electrical service and rates within the City of Port Angeles are defined in Titles 13 and 14 of the Port Angeles Municipal Code, which may be viewed on the Internet at [www.cityofpa.us](http://www.cityofpa.us). Nothing in this document supercedes or modifies the requirements of those Titles. The requirements described herein are intended to be used as a simplified guide by consumers and electrical contractors in wiring facilities that will receive electric service from the City of Port Angeles (PA) Light Utility, a part of the Public Works and Utilities Department, referred to in this document as "PW&U." We recognize personal assistance from our staff may be required, and encourage contacting the Engineering Services Division of the PW&U (PW&U Engineering) at (360) 417-4700 to discuss specific electric service requirements. Copies of this chapter are available at the Public Works Engineering office in City Hall or on the City's website, [www.cityofpa.us](http://www.cityofpa.us).
- B. Generally, the City of Port Angeles will be the serving utility inside the limits of the City of Port Angeles, and Clallam County Public Utility District #1 (PUD) will provide service outside the city limits. Occasionally, to avoid duplication of facilities or for some other mutually agreed upon reason, the PW&U will serve some customers outside city limits, or the PUD may serve some customers inside city limits. Any questions concerning the serving utility should be directed to either the PW&U Engineering or PUD Engineering department before any installation is done.

#### 8.02 CODES AND ORDINANCES

- A. This document does not replace or supercede any electrical wiring codes established by municipal, state, or national authorities, but does contain supplementary information considered pertinent to the safe use of electric power. All new or remodeled installations shall comply with all applicable provisions of the latest editions of the following standards, codes, laws, and ordinances:
1. National Electrical Code (NEC), NFPA-70
  2. National Electrical Safety Code (NESC), IEEE-C2
  3. State of Washington Administrative Code (WAC)
  4. Occupational Safety and Health Administration (OSHA)
  5. Nationally Recognized Testing Laboratories (NRTL), such as UL, ETL, etc.
  6. City of Port Angeles municipal code and ordinances.
- B. State and Federal OSHA laws prohibit any work taking place within at least 10 feet (horizontal distance) of a high voltage overhead power line. Some lines require even greater clearance distance. The party performing any work near power lines shall notify the PA Light Utility at least three days prior to commencing work. The PA Light Utility must approve any proposed method of accomplishing the activity safely.

## CHAPTER 8 – ELECTRIC UTILITY

### 8.03 APPLICATION FOR SERVICE

- A. It is important that PW&U Engineering be provided as early as possible with accurate load information and the date when the customer will require service, so all necessary arrangements for service may be completed of the desired schedule. Commercial and industrial services normally require considerable advance planning by PW&U Engineering in order to serve the load. Installations requiring pad mounted transformers or other equipment not in stock may require 6-12 months lead time before delivery.
- B. For applications for commercial, industrial, residential subdivisions, mobile home parks, or apartment complexes, the request for service should accompany applications submitted to the City of Port Angeles Community and Economic Development Department, and include a site plan with existing and proposed utility locations.
- C. Commercial or industrial permit applications shall include the following information:
1. Site plan with preferred electric service and meter locations
  2. Single-line diagram of the electrical system.
  3. Load summary with information on connected loads for lighting, receptacles, water heating, cooking, electric heating, air conditioning, motors, and sufficient information on equipment operation that the demand of the load can be estimated.
- D. Before new installations will be scheduled for construction, the customer must provide PW&U Engineering with a summary of electrical load information as itemized in the "Electrical Service Information Form," Appendix A of this Section, including the following names and contact information:
1. Owner
  2. Owner's Representative
  3. Contractor
  4. Electrician
  5. Excavator (For underground services)
- E. Local ordinances require that a permit procedure be followed before the utility service can be energized. Washington State law requires the electrical installation to be approved by the City of Port Angeles electrical inspector before it can be energized by the PA Light Utility.
- F. Applications for service or electrical permits may be made at Port Angeles City Hall, 321 E. Fifth St. Allow 72 hours for the permit to be processed prior to performing any on-site work.
- G. PW&U Engineering staff is available to advise customers on service requirements, energy conservation, and other problems related to electric energy utilization for new, existing, and reconstructed installations. The customer or installing contractor is responsible for any damage to City equipment unless adequate notice is given to the City regarding changes or additions.

### 8.04 POWERLINE EXTENSIONS

## CHAPTER 8 – ELECTRIC UTILITY

- A. The total cost of extending of PA Light Utility power lines are paid for by the customer requesting service. An estimate of the line extension cost will be made by PW&U Engineering and provided to the customer. Customer's payment must be received before work can be scheduled. Refer to paragraph 8.060 for other requirements. The customer is to provide all required easements, right-of-way clearing, ballasting and grading, surveying, property pin and building locations, and trenching and backfilling if applicable. Grading must be within 6 inches of final grade before construction begins.
- B. Within certain guidelines, partial refunds of construction costs may be made if other customers later connect to the same line extension within certain time limits. Consult City of Port Angeles Public Works Engineering for specific details.

### 8.05 TYPES OF SERVICE FURNISHED

- A. Electric service available is 60-Hertz, alternating current, single or three phase. The nominal secondary voltages from either overhead or underground distribution lines in the service area are as follows:
  - 1. Single phase, 120/240 volts, three-wire, grounded
  - 2. Three phase, 208Y/120 volts, four-wire, grounded, wye
  - 3. Three phase, 480Y/277 volts, four-wire, grounded, wye
- B. Under certain limited conditions with PW&U engineering approval, and at the PW&U's option, service may be provided at the following voltages:
  - 1. Single phase, 120/208 volts, three-wire, grounded (200 Amps or less)
  - 2. Three phase, 120/240 volts, four-wire, grounded, delta

### 8.06 PERMANENT SERVICE CONNECTION

- A. Only authorized City employees shall make the permanent connection or disconnection of utility service to a building or structure.

### 8.07 TEMPORARY SERVICE CONNECTIONS

- A. Temporary service is typically defined as electric service to a site for less than one year. Temporary power may be provided to a site for construction if PA Light Utility facilities exist in the area. When construction is complete, the temporary service is replaced by permanent service. If power is not readily available at the site, contact PW&U Engineering for further requirements. The owner or contractor must pay in advance the full cost of any modifications to the PA Light Utility system, including installation and removal costs. Credit will be given for any material with salvage value.
- B. Service characteristics shall be 120/240V, 3-wire, single-phase, 100 or 200 amp. Provide 6-terminal, UL approved meter socket. Contact PW&U Engineering for other service types.
- C. Installation must comply with all NEC requirements. All standard NESC minimum clearances must be maintained for service conductors, even for temporary installations.

## CHAPTER 8 – ELECTRIC UTILITY

- D. Service conductors may not cross other people's property. If service conductors will pass through brush or trees, a path must be cleared to allow PA Light Utility personnel to install a line without contacting trees or limbs. Maintaining a clear path is the owner's responsibility.
- E. Refer to Figures 1, 2, and 9 in Appendix B for further installation details.
- F. Procedure to establish service:
  - 1. Establish a utility billing account at the City of Port Angeles, City Hall. Contact Customer Service at (360) 417-0411 for further information.
  - 2. Obtain an electrical permit at the City of Port Angeles, City Hall. Call the Port Angeles Electrical Inspector at (360) 417-4735 for further information.
  - 3. Install temporary electrical service. CALL BEFORE YOU DIG for locations, 1-800-424-5555.
  - 4. Request an electrical inspection from the Port Angeles electrical inspector.
  - 5. After approval by the inspector, service will typically be connected during the next business day.

### 8.08 SEALS

- A. The purpose of seals placed by the PW&U on meters and associated service equipment is to prevent injury and/or tampering. All unmetered enclosures or raceways must be visible and have provisions for installation of a PW&U seal.
- B. Under normal circumstances, these seals are not to be removed except by the PW&U. If an emergency should require seal removal without prior notification, the PW&U must be notified as soon as possible so the installation can be inspected and the seal replaced.
- C. **Non-emergency or unauthorized seal removal will result in financial and possibly legal penalties. Tampering with a seal, even without theft of service, is a violation of city and state laws (Municipal Code 13.10.050).**

### 8.09 RESALE OF ELECTRICITY

- A. The resale of electricity is prohibited.

### 8.10 SERVICES

#### A. GENERAL

- 1. The location of the service entrance on the Customer's premises is an important consideration to both the customer and the PW&U. The service entrance shall be located to make the meter and service easily accessible from the utility distribution, and convenient for the installation, operation, and maintenance of City meters and equipment. PW&U Engineering shall be consulted in order to designate the point of attachment for overhead service drops, underground service laterals, preferred meter and service outlet locations, current transformer and terminal cabinet enclosures. PW&U Engineering must also be consulted if any variations from these designated locations is desired.

## CHAPTER 8 – ELECTRIC UTILITY

2. For secondary voltage service, PA Light Utility will provide, install, and maintain transformers, meters, and overhead conductors that are defined in Article 100 of the NEC as the "Service Drop." The customer will provide, install, and maintain all service equipment, overhead service risers on poles, overhead service entrance risers and weatherheads, underground conductors and raceways, enclosures, and meter sockets, and will provide rights-of-way and space for the installation and maintenance of PA Light Utility facilities.
3. **Only one service drop or service lateral will be provided for any single building, except as allowed by NEC Article 230.2.**
4. Where two or more meters are grouped, each meter position must be clearly and permanently identified by means of a metal indentation or plastic engraved label indicating the particular location supplied. Attach labels with screws or rivets. Services will remain in Contractor's name until labeled and wiring is verified.
5. Unmetered service wires shall not be routed in the same conduit, raceway, or wiring gutter with metered load conductors.
6. All exposed service entrance conductors must be installed in continuous, galvanized rigid steel conduit or schedule 80 PVC.

### B. PROTECTION

1. The customer is responsible for providing barrier posts for the protection of electrical equipment. When vehicles or other equipment may be near City equipment, a barrier post or posts of concrete-filled, six-inch diameter steel conduit will be required. Contact PW&U Engineering for details.
2. The customer shall ensure that trees, shrubs, and other vegetation will not interfere with the proper operation, maintenance, and meter reading of City facilities. Tree trimming to protect overhead lines on private property is the responsibility of the property owner. The PA Light Utility will temporarily de-energize secondary overhead service conductors at no charge to facilitate tree trimming.

### C. SERVICE TYPE

1. New overhead service will be supplied to any building or premises where there are existing overhead facilities immediately adjacent. Service in areas designated by PW&U Engineering as an underground district must be underground. Portions of the downtown area designated for future conversion to underground must be installed underground.
2. Refer to Section 8.150 for additional details of customer equipment that may be connected to different service types.

### 8.11 OVERHEAD SERVICES

- A. In areas served from overhead lines, an overhead service drop will be installed by the PA Light Utility from their distribution line to the point of connection to the customer's service entrance conductors at the service outlet on the customer's residence, building or structure. Maximum lengths of service drops depend on service size and should be verified with PW&U Engineering before installing any service equipment. The customer does not install the service drop, but is required to provide a point of attachment high

## CHAPTER 8 – ELECTRIC UTILITY

enough and strong enough to allow PA Light Utility to install the service line and maintain the clearances required by the NESC.

- B. The customer will provide a point of attachment which can be reached with a single span of wire from an adjacent utility line with minimum clearances to ground, roofs, and structures maintained as specified in the NESC. Refer to Figure 16 in Appendix B for some commonly encountered clearance requirements. Under certain conditions of terrain and distance, PW&U Engineering will require a pole to maintain clearances. When required, poles will be provided and installed by the PA Light Utility at the customer's expense. There should be no overhang of adjacent property, and the route of the service drop must be without obstruction by buildings, trees or other objects. The point of attachment will normally be on the building wall facing the nearest utility line, and/or on a service mast capable of withstanding the tension of the service drop, and shall not be adjacent to windows, doors, porches, etc.
- C. The exact height of the point of attachment of the overhead service drop will be determined by the above clearance requirements, but will **not be less than 12 feet** and not over 25 feet above finished grade, and shall be within 4 feet of the edge of any roof overhang. Supports for service drops must be extended from and tied into the main structural members of the building and not be mounted on fascia trim. Attachment points may not be on fascia or trim. The customer must bring his service entrance conductors to this point for connection by the PA Light Utility to the service drop. Refer to Figure 4 in Appendix B.
- D. It is strongly suggested that the service entrance be located to avoid having conductors pass near trees, over buildings, accessible roofs, or other obstructions, if at all possible. The customer is responsible for regular trimming of trees and bushes on their property to maintain a clear path for the overhead conductors. Minimum clearances required by the NESC must be maintained. **Conductors shall not pass over or within 10 feet horizontally of the edge of swimming pools, spas, etc.**
- E. No attachments are allowed to PA Light Utility overhead facilities by customers unless provided by contract.

### F. SINGLE-FAMILY OVERHEAD SERVICE

- 1. The standard single-family residential service is 200 amps, 120/240 volts, single-phase. If the distance between PA Light Utility's distribution line and the customer's point of connection exceeds 75 feet, PW&U Engineering may require the customer to install and maintain poles, wires and/or other equipment on the property. Larger service sizes require contacting PW&U Engineering for specific requirements.

### G. MULTIPLE-FAMILY OVERHEAD SERVICE

- 1. The PA Light Utility will extend an overhead service drop from its distribution lines to the point of connection to the customer's service entrance conductors at the service head.
- 2. PW&U Engineering requires the grouping of service heads at a common location and will not extend service drop conductors from the point of attachment to the individual service heads. It will be the customer's

## CHAPTER 8 – ELECTRIC UTILITY

responsibility to bring his service entrance conductors from the service head to the PA Light Utility's service drop.

3. Multiple single-family dwelling units on a single lot or property require separate services and meters.

### H. NON-RESIDENTIAL OVERHEAD SERVICE

1. The point of attachment for non-residential installations must be approved by PW&U Engineering prior to the installation of the customer's service equipment. Where more than one service entrance of the same voltage and phase to a building is necessary, the service entrance(s) must be grouped so they may be served from the same set of service drops. Any additional service wire attachment must be approved by PW&U Engineering.
2. Pole-mounted transformer installations are limited to a size which can be safely supported by a single pole. Electrical loads requiring more than a 500 kVA three-phase transformer will require underground service from a pad-mounted transformer.

### 8.12 UNDERGROUND SERVICES

- A. Where underground service is requested or required, the customer shall pay the extension costs described herein, and provide the trenching, backfilling, and secondary conduit as described. Before making any preparation for underground service, customer shall contact PW&U Engineering to determine an estimate of the costs and the customer's responsibilities. The cost estimate provided will include primary conduit to be installed by the PA Light Utility in a trench provided by the customer. The estimated cost must be paid in full before work is scheduled.
- B. If the actual costs and material quantities exceed the estimate provided for the designed installation, the customer may be charged additional. If actual costs are less than the estimate, the excess charges will be refunded to the customer.
- C. Customers adequately served by existing overhead distribution facilities, but desiring underground service in accordance with these requirements, should contact PW&U Engineering for details of the policy for conversions.
- D. Trenches
  1. Depth:

The customer is to provide the trench for the installation of conduit and conductors. The trench shall be a minimum depth of 30 inches deep measured from final grade. More depth may be required for higher voltage cables. Refer to Figure 9 in Appendix B of this document. Conductors with less than the minimum cover require mechanical protection, which will be provided by the customer to PW&U Engineering specifications. Customer shall provide pumping or other measures to ensure reasonably water-free trenches.
  2. Width:

Trench shall be per Figure 9, unless a narrower width is approved by PW&U Engineering. Refer to Figure 9 in Appendix B of this document. A narrower trench will normally be approved for a single service or where splicing or other

## CHAPTER 8 – ELECTRIC UTILITY

work will not be done in the trench. To facilitate connections at service pedestal and building, trench to be 24 inches wide, for a distance of 60 inches from a pedestal or building service.

3. Backfill:

Trench shall be clear of rocks or roots greater than 2 inches in diameter. The customer will be responsible for backfilling the trenches he provides to 95% compaction. The backfill material must not contain any sharp or foreign objects. Contact PW&U Engineering for the method to be used to protect conductors to be placed in rocky ground.

4. Joint Uses:

Communication, signal and other electrical conductors may be placed in the same trench as the power conductors, provided that the installation is in accordance with PW&U Engineering specifications, and is mutually agreed to by all utilities concerned. The PA Light Utility will not install electrical conductors in a common trench with non-electric utilities such as water, gas and sewer, unless unusual conditions such as adverse soil or route restrictions exist. All such installations require the prior approval of PW&U Engineering.

### E. Raceways

1. Rigid steel and Schedule 40 PVC are acceptable materials for raceways installed by the customer, except Schedule 80 PVC must be used under vehicle driving areas and where exposed above grade, except when allowed otherwise. Minimum bend radius shall be ten times the conduit diameter. In no case shall the total of all bends in a service run exceed 360 degrees.
2. Customer owned underground conduits shall be installed prior to setting the transformer. Customers are not allowed to dig under existing transformers to install conduits.
3. Conduits for primary cables shall not be installed under buildings. Service conductor conduits may be under buildings to the extent allowed by the NEC.

### F. CLEARANCES FROM SWIMMING POOLS

1. Underground conductors shall not be located under a swimming pool or within 5 feet of the inside wall of a pool.

### G. UNDERGROUND SERVICE – RESIDENTIAL OCCUPANCIES

1. For underground secondary services to residential occupancies, including single and multiple-family and mobile home parks, the customer's underground conductors will be provided, installed, and owned by the customer. Normal size for a residential service is 4/0 aluminum triplex. It is the customer's responsibility to determine and provide a larger size for long runs or heavier than normal loads. PW&U Engineering approved duct, furnished and installed by the customer, is required for conductors on private property when crossing under a road, driveway, concrete area or building. The customer or developer will be responsible for the cost of all trenching, duct, sand, excavation, and backfill on the premises or within the confines of the project or subdivision to be served and, in some cases, for a distance outside the project to connect to PA Light Utility facilities.

## CHAPTER 8 – ELECTRIC UTILITY

2. If a transformer installation is necessary, consult PW&U Engineering for customer responsibilities and detailed installation specifications. Customer is to provide easements for locating transformers and/or pedestals on Customer property. Such equipment shall not be located in public right-of-way. Where a pad-mounted transformer is installed in a location where it might be struck by a motorized vehicle, the customer is to install and maintain PW&U Engineering approved barrier posts to protect the transformer.
3. The underground service lateral will be installed, owned and maintained by the customer from PA Light Utility's distribution pedestal to the customer's service location.
4. For service entrance equipment, with a code-calculated demand load of 400 amperes or less, the customer must extend his service entrance conductors from the meter socket into the service trench and continue to PA Light Utility facilities.
5. Single-phase 120/208V loads cannot exceed 200 amperes. For code-calculated 120/240V, single-phase loads greater than 320 amperes, current transformer metering will be required. The customer is to provide and install a current transformer (CT) cabinet. This CT cabinet should be located on the exterior of the building. This cabinet may be placed on the interior by special permission only. The customer will route the service lateral conductors to and from landing lugs for bar-type current transformers in this CT cabinet. The PA Light Utility metering department will provide the current transformers, which shall be mounted in the CT cabinet by the customer. Refer to Section 8.140 for additional metering installation details.
6. The customer's service entrance equipment should be located on the building structure so that the connection point of this equipment to the PA Light Utility facilities is on the side nearest those facilities from which the service lateral will originate. The customer or contractor should contact PW&U Engineering for the location and routing of the service lateral prior to the start of building construction.

### H. UNDERGROUND SERVICE TO MOBILE HOMES

1. For underground service to a mobile home, the customer's service entrance equipment must be located on a pedestal approved for the purpose. When the meter may be subject to physical damage, barrier posts or other suitable protection must be installed and maintained by the customer.
2. For underground service in mobile home parks, the customer must extend the service entrance conductors from the pedestal to PA Light Utility facilities.
3. Trenches and raceways in mobile home parks provided for service conductors must be located so as to avoid passing under the pad, foundation, or area provided for the mobile home.

### I. Non-Residential Underground Service

1. For underground service to commercial or industrial buildings or projects, the customer or developer is responsible for all trenching, backfilling, secondary raceways, and transformer pads or vaults within the project. If a transformer installation is necessary, the customer is to provide space for the transformer that meets the current PW&U Engineering requirements. The underground service lateral from a PA Light Utility distribution pole or pad mounted transformer to the customer's service entrance point (normally on or within the building), will be

## CHAPTER 8 – ELECTRIC UTILITY

installed, owned, and maintained by the customer. Customer must determine conductor sizes to maintain voltage drop within acceptable limits.

2. Conduit for secondary conductors is required. All conduits, cables, and busways into pad-mounted transformers must enter through the bottom in the designated locations.
3. High voltage conductors will be installed by the PA Light Utility in City-provided raceways in customer-provided trenches. Contact PW&U Engineering for raceway trenching requirements for primary voltage conductors.
4. Where a pad-mounted transformer is installed in a location where it might be struck by a motorized vehicle, the customer is to install and maintain PW&U-Engineering approved barrier posts to protect the transformer.
5. Where a customer's raceway is to extend to a utility pole, the customer is to install the 90-degree steel, fiberglass, or schedule 80 PVC bend at the base of the pole. The customer will also provide the first 10 feet of steel or schedule 80 PVC conduit on the pole and provide all standoffs. PA Light Utility crews will install the customer raceway up the pole. PW&U Engineering will designate the proper position on the pole for the raceway prior to the installation of the 90-degree bend at the base of the pole. Refer to Figure 15 in Appendix B of this Section.

### 8.13 SERVICE AT PRIMARY VOLTAGE

#### A. General

1. The PA Light Utility will provide delivery to qualified customers directly, without transformation, from the high-voltage or "primary" distribution system to the location in which service is requested, provided that:
  - a) The distribution system nominal phase-to-phase voltage is 12,470 volts or higher;
  - b) Service at primary voltage will not, in PW&U Engineering's judgment, adversely affect the operation of the distribution system or other customers' service thereon;
  - c) Such service can be supplied in a safe and reliable manner.
2. All customers requesting service at a primary voltage must agree to those special requirements that PW&U Engineering may from time to time establish as necessary.

#### B. Customer Equipment

1. The customer receiving service at primary or higher voltage shall own poles, conductors, cables, transformers, and associated protective devices on the customer's side of the meter. All such equipment, its arrangement and its operation will be subject to PW&U Engineering approval. Except by prior written approval of PW&U Engineering, three-phase transformers connected to primary voltage lines are to have a grounded wye high-side winding and a grounded wye low-side winding, with a four or five legged core. Transformer specifications are available upon request from PW&U Engineering.
2. To assure timely restoration of service in case of failure, all primary voltage customer-owned wiring and equipment, including transformers and associated protective devices, should be the same types and characteristics as those used

## CHAPTER 8 – ELECTRIC UTILITY

by the PA Light Utility. If the customer desires the PA Light Utility to perform any maintenance, the type, arrangement, and operation of such equipment is be subject to PW&U Engineering approval prior to purchase.

3. The customer is responsible for all operation and maintenance of facilities on the customer side of the point of delivery.

### C. UTILITY EQUIPMENT

1. PA Light Utility will provide at Customer expense the pole or pad-mounted enclosure to contain the primary metering equipment; and in addition, will normally provide a disconnecting means at or near the point of delivery to disconnect the customer's system from the PA Light Utility system.
2. Unless otherwise designated, the point of delivery shall be taken as the load side of the pole or pad-mounted enclosure containing PW&U's primary metering equipment.

### 8.14 METERING

- A. The utility's rate schedules require the delivery of each class and type of electrical service through one meter to one customer at a time.
- B. Customers or contractors are not authorized to relocate any meter belonging to the PA Light Utility or interfere in any way with the meter or its connection. The customer or contractor may not remove the meter to disconnect the service. The PA Light Utility will provide this service if requested. **WITH SOME TYPES OF METER BASES, REMOVAL OF THE METER DOES NOT DE-ENERGIZE THE SERVICE.** The meter must be reinstalled in the meter socket after repairs or modifications of the service is completed. The customer or contractor is to promptly notify the PA Light Utility when repairs or modifications have been completed.

### C. ACCEPTABLE METER SOCKETS

Meter sockets shall be manufactured in accordance with the current Standards for Safe Meter Sockets and be NRTL listed. Multiple meters on a single building shall be manufactured meter clusters. Any main breakers or unmetered raceways must have provisions for seals on access panels.

### D. SELF-CONTAINED METER SOCKETS

1. The PA Light Utility requires a self-contained, ring or ringless socket-type meter installation on the line side of single-phase service equipment when the ampacity of the service entrance conductors is 200 amperes or less. The PA Light Utility does not accept 400 amp self-contained meter sockets. PA Light Utility will accept a 400 amp service (two 200 amp panels, not 225 amp) on a 320 amp, 120/240V, single-phase direct-metered service with locking jaws/bypass (manually operated), and not a bolt-in type socket. Non-residential installations must provide panel schedule(s) demonstrating less than 320 amperes of connected load.
2. Three-phase services of 200 amperes or less also require a self-contained, ring or ringless socket-type meter. The meter socket, complete with terminal lugs, meter jaws and sealing means, shall be provided by the customer. Services of

## CHAPTER 8 – ELECTRIC UTILITY

480Y/277 V or 240/480 V will require a safety socket with provisions to de-energize socket jaws for meter exchange.

<u>TYPE OF SERVICE</u>	<u>NUMBER OF TERMINALS</u>
Three wire, single phase	4
Three wire, 120/208 volts, single phase	5
Four wire, three phase, grounded	7

3. Lever and block or shunt type bypasses are required for all non-residential self-contained meter installations. Automatic bypasses are not allowed. Provisions shall be made for a test switch when current transformer metering is installed. When a meter socket is replaced for any reason, the new socket must meet current standards.
4. No more than one conductor may be connected to an individual load side terminal of a meter socket, except for 320 amp class meter socket.

### E. MOUNTING OF METER SOCKETS

1. Sockets must be plumb in all directions and securely mounted to a rigid surface. Conductors must be securely fastened to their respective terminals and must be arranged in a manner which will not interfere with the installation of the meter or cover or with the operation of a jaw-clamp device.
2. PA Light Utility does not allow the use of enclosures over meters. Meters shall be located to be visible and accessible to PA Light Utility personnel 24 hours a day, unless permission is granted in advance by PW&U Engineering for special conditions.

### F. CURRENT TRANSFORMER METERING

1. Current transformer metering is required where the service entrance ampacity of three-phase service entrances exceeds 200 amperes, or the service entrance ampacity of single-phase entrances exceeds 320 amperes. Single-phase 120/240V entrances between 200 amperes and 320 amperes will be metered with a self-contained meter and meter socket rated for 320 continuous amperes.
2. The current transformers are to be provided and installed by PA Light Utility in a customer-owned, sealable steel cabinet with transformer mounting provisions and current transformer (CT) landing pads, securely mounted on a rigid surface (2 x 4 stud or equivalent). C.T. enclosures shall be mounted such that the bottom of the enclosure is no higher than 3 feet above finished grade and the bottom of the enclosure is no less than 6 inches above finished grade.
3. This cabinet is to contain only the service conductors, current transformer landing pads, and PA Light Utility equipment, and is to be mounted in a readily-accessible outdoor location. The cover of the CT enclosure shall be free of meters or other equipment. Meter sockets and current transformers shall not be mounted in or on PA Light Utility poles, pad-mounted transformers, or other equipment.
4. Minimum acceptable sizes for the current transformer cabinets are:

<u>Service Size</u>	<u>Enclosure Size</u>
---------------------	-----------------------

## CHAPTER 8 – ELECTRIC UTILITY

400 Amperes Single Phase	24" x 36" x 11"
800 Amperes Single Phase	36" x 36" x 11" with hinged cover
400 Amperes Three Phase	36" x 36" x 11"
800 Amperes Three Phase	36" x 48" x 11" with hinged cover
Service Entrance over 800 Amps:	Switchboard Section

5. For service entrances of over 800 Amperes, the CT enclosures shall be part of the Customer's service panels or switchgear. **Service equipment showing compartment size shall be submitted to PW&U Engineering for review prior to purchasing and installing equipment.** The CT space shall have bus bars through the CT's that are removable from within the CT window. The CT's shall be furnished and installed by PA Light Utility. Cables shall not be brought through the CT window.
6. Current transformers shall be installed in such a manner as to be readily accessible after all bussing is in place. Neutral connections for metering shall be readily accessible and sealable. All sections of the switchgear that contain metering equipment or unmetred conductors shall have provisions for sealing compartment doors or covers.
7. Current transformer cabinets or switchgear with built-in meter sockets are not allowed. The customer is to provide and install the meter socket and a rigid steel conduit with a non-conductive pull line between the current transformer cabinet and meter socket, along with bonding by code-approved methods. Conduit will normally be limited to runs of 50 feet or less with not over 270 degrees in bends (consult PW&U Engineering if over 270 degrees in bends are required), and shall have a diameter of one (1) inch. Removable conduit cover fittings are not allowed.
8. Conduit runs longer than 50 feet in length must have PW&U Engineering approval prior to installation and will be granted only if, in the opinion of PW&U Engineering, a satisfactory meter location is unattainable within the normal length. Conduit sizing will be specified by PW&U Engineering for each extra-length run, based on the total length and number of bends.
9. The meter socket for current transformer metering is to have space below the socket for a PA Light Utility test switch. The minimum width of the enclosure is to be 11 inches. The enclosure is to contain a perch, drilled and tapped, for a test switch. The test switch will be furnished and installed by PA Light Utility. Meter sockets with circuit closures by pass-clips will not be approved for new installations or for modifications of existing service. Meter socket shall be installed outdoors in an accessible location even where CT's are mounted in indoor switchboards.
10. The number of terminals required in the meter socket are:
  - a. Three wire, single phase service: 6 Terminals
  - b. Four wire, three phase, grounded wye service: 13 Terminals

### G. kVA METERING

Commercial load metering for services larger than 400 amps at 120/208-240V, or 200A at 240-277/480V utilize kilovolt-ampere (kVA) demands. This method of metering inherently incorporates the impacts of power factor. No separate penalty or metering is applied to monitor for poor power factor. It is the customer's responsibility to monitor their power factor, and implement corrections as required to reduce their billing.

## CHAPTER 8 – ELECTRIC UTILITY

### H. INSTRUMENT TRANSFORMER INSTALLATIONS OVER 600 VOLTS

High-voltage instrument transformers and transformer-type meters may be required for large customers taking service at primary voltage. PW&U Engineering should be consulted before construction begins, to establish a mutually satisfactory location for the point of delivery and metering details.

### I. METERING ON A POLE OR IN A CITY ENCLOSURE

Meters will not be permitted on transformers or pedestals, except when in PW&U Engineering's opinion a satisfactory location for the installation of metering cannot be found. Meters may not be mounted on PA Light Utility poles. City-designated underground non-residential districts may require pedestal-mounted metering. Contact PW&U Engineering for details.

### J. TIME-OF-USE METERING

Time-of-use metering is an option available to all customers, and may be required for large commercial and industrial loads. Contact PW&U Engineering for specific requirements and rates.

### K. SUB-METERING

Sub-metering is prohibited for resale or apportioning of costs. Sub-metering may be approved in writing under certain conditions, at the option of PW&U Engineering for marinas, load management systems, research or other such reasons.

## 8.15 CUSTOMER EQUIPMENT AND CHARACTER OF SERVICE

### A. GENERAL

1. The customer's electrical equipment and devices are to have characteristics such that the distribution system is effectively utilized and undue interference with PA Light Utility service to other customers does not occur.
2. The customer's equipment shall be designed to perform satisfactorily within the standard voltage ranges and frequency provided on the PA Light Utility system. Insofar as is practical, the PA Light Utility will endeavor to maintain standard voltages and frequency on its distribution systems. Subject to variations, normal service is plus or minus 5% of nominal voltage, and frequency will be as provided by Bonneville Power Administration (BPA) – 60 hertz plus or minus 1 hertz. Momentary excursions outside those limits can occur, particularly during storm and fault conditions. It is the customer's responsibility to protect their equipment from any damage that could result from such variations, loss of a phase, or from a complete loss of power.
3. PW&U Engineering reserves the right to inspect and test any equipment connected to its lines and to require any information necessary to determine the operation characteristics of the equipment. Prior to purchase, the customer shall submit information to PW&U Engineering regarding any equipment which might cause interference with service to other customers or require additional facilities for its satisfactory operation.

### B. SINGLE-PHASE SERVICE

## CHAPTER 8 – ELECTRIC UTILITY

1. No individual single-phase motor larger than 5 horsepower, and no X-ray equipment or welders may be connected without prior approval in writing from PW&U Engineering. In addition, air conditioners and heat pumps larger than 3 tons require prior PW&U Engineering approval. This equipment may cause unavoidable voltage dips objectionable to some customers.
2. Any residential space heating or water heating appliance having a total capacity greater than 7 kilowatts shall be so designed and controlled that not more than 7 kilowatts will be switched on or off at any one time.
3. PW&U Engineering, at its option, may limit the maximum single-phase service where, in PW&U Engineering's judgment, the customer's connected load is of a size that three-phase is necessary. This limit is typically 600 amperes total connected load in low density areas, and less in high density areas.

### C. THREE-PHASE SERVICE

1. Three-phase service, if available in the area, will normally be provided to non-residential customers upon request if there is at least one three-phase motor of 5 horsepower or larger, or the total load is greater than 15 kilowatts. Three-phase service for smaller loads must be approved in advance by PW&U Engineering.
2. The manner in which single-phase load is connected by the customer is critical with three-phase service. On 208Y/120 volt or 480Y/277 volt three-phase services, all single-phase loads should be divided evenly among the three phases.
3. In overhead districts, both 208Y/120 volt and 240/120 volt delta three-phase service may be available. The selection of which voltage is to be supplied is at the option of PW&U Engineering and will depend upon the characteristics of the distribution system in the area and the customer's electrical needs.
4. Three-phase, 480 volt service will not be supplied where the total load to be served is less than 50 kilowatts, except where the load consists of a single motor with a nameplate rating of at least 30 horsepower.
5. Three-phase delta service will not be supplied from underground systems.
6. A contract or payment of additional charges may be required for extension of PA Light Utility primary and secondary voltage conductors and the transformer installation.
7. PW&U Engineering may, at its option, limit the maximum load served (three-phase) through a single point of delivery to the capacity of the largest standard size transformer. In general, prior agreement should be obtained for service to three-phase loads larger than 1,500 kilovolt-amperes total connected load.

### D. EQUIPMENT PROTECTION

1. To assure adequate safety to personnel and equipment, the customer shall provide and maintain NRTL-approved protective devices in each phase to protect all motors against overloading, overheating, improper phase rotation, short circuits, ground faults and low voltage, and to protect all three-phase motors against single-phasing.
2. The customer shall provide and maintain any surge suppressors, voltage regulators, or other devices required for protection of sensitive electronic equipment. Equipment should protect against voltage spikes, harmonics,

## CHAPTER 8 – ELECTRIC UTILITY

lightning, line noise, impulses, transients, and electro-magnetic or radio interference.

3. The PA Light Utility is not responsible for damage to Customer equipment due to the failure of the Customer to provide adequate protection.

### E. LOAD STARTING/STAGING

1. Reduced-voltage starters are required on all motors rated in excess of 40 horsepower at 208 volts, or over 75 horsepower at 480 volts, except as follows:
  - a. Permission is granted by PW&U Engineering to omit the reduced-voltage starter.
  - b. Reduced-voltage starters are usually required on all motors rated equal to or greater than 100 Hp if the customer receives delivery from PA Light Utility at a voltage greater than 12,000 volts.
  - c. If the customer receives delivery at a voltage greater than 60,000 volts, contact PW&U Engineering for requirements.
2. Large single non-motor electric loads over 50 kVA are usually required to be “staged” so that no portions exceeding 50 kVA be placed on line simultaneously. The delay between stages should exceed five seconds in length. With prior written approval from PW&U Engineering, exceptions may be granted from these guidelines.
3. PW&U Engineering will furnish information regarding permitted starting currents. The starting currents permitted will depend upon the frequency of start of the load or motor, the size and character of the customer’s load and the design of the distribution system in the area, and will generally be equivalent to the maximum starting current which, in PW&U Engineering’s opinion, can be supplied without undue interference with service to other customers.
4. Voltage flicker calculations will be done on an individual basis. The amount and frequency of voltage drops must be within guidelines of the Institute of Electrical and Electronics Engineers (IEEE) Standard 1453.
5. No additional PA Light Utility facilities will be installed, or existing facilities modified, to reduce voltage fluctuations on an individual customer’s service caused by the starting of his motors or other loads until after approved reduced-voltage starters, capacitors, or other corrective devices have been installed by the customer. If additional PA Light Utility facilities are required, or modifications of existing facilities, they will be installed or modified at the customer’s expense.

### F. INTERFERING LOADS

1. Whenever a customer’s utilization equipment has characteristics that cause undue interference with utility service to other customers, the customer shall make changes in such equipment or provide, at his expense, additional equipment to eliminate the interference. Where practical, PA Light Utility may furnish the additional equipment required at the customer’s expense.
2. Additional facilities, such as separate utility transformers and a separate service, can be used to minimize voltage fluctuations on secondary voltage circuits for devices such as welders, induction heating equipment and X-ray machines. Where the operation of this type of equipment causes undue voltage fluctuations on primary voltage lines, the additional equipment required may include a separate

## CHAPTER 8 – ELECTRIC UTILITY

primary voltage line. Where practical, PA Light Utility will furnish additional equipment at the customer's expense.

3. High-frequency equipment such as electronic heating equipment, spark discharge devices, radio transmitting equipment, etc. and equipment that generates harmonics, such as a variable frequency drive motor or electronic lighting ballasts, shall be designed and operated so as not to create disturbances on PA Light Utility's electrical system which might interfere with the proper operation of communication, radio, television, remote control or other utilization equipment of other customers. Harmonics must be filtered to be within the limits specified in Institute of Electrical and Electronics Engineers (IEEE) Standard 519.

### G. POWER FACTOR

1. Large commercial metering is based on kilovolt-ampere (kVA) demand and kilowatt-hour (kWH) usage. No specific penalty is assessed for low power factor. Refer to Section 8.140 for additional details.

### 8.16 EMERGENCY OR STANDBY GENERATORS

- A. Permanently installed emergency or standby generators are to be connected to the customer's wiring system by a permanently installed transfer switch intended for that purpose. The transfer switch is to disconnect all conductors including the neutral, if any, connected to the PW&U system prior to connecting the generator to the conductor supplying the load. The transfer switch is to be designed and installed so that connection of the generator to the PW&U system is physically impossible for any mode of operation. Closed-transition transfer switches are not allowed, but a momentarily overlapping neutral is acceptable. Panelboard breaker interlocks are not permitted in place of actual transfer switches. Compliance with these provisions is necessary to prevent serious or possibly fatal accidents.
- B. Temporary generators may only be connected to a permanent wiring system through permanently installed transfer switches that prevent connection of the generator to the service entrance conductors.
- C. Parallel generation is the parallel production of electric energy, where sources of generation other than PA Light Utility's are connected for parallel operation with the PA Light Utility system. Such sources, when customer-owned, may provide all or a part of the customer's requirements, or customers may sell directly all or part of their output to the PA Light Utility. Customer sources may include, but are not limited to, ship-to-shore ties, wind turbines, waterwheels, steam turbines, fuel cells, solar conversion, and geothermal devices. Each proposal for parallel generation will be handled on an individual basis and will require a special contract between the customer and PW&U.
- D. For parallel generation, the customer must provide a lockable disconnect switch with a visible air gap which disconnects all conductors, including neutrals and grounds, to isolate their generation from PA Light Utility system. This disconnect switch must be accessible to the PA Light Utility, and PA Light Utility shall have the right to lock the switch open whenever necessary to maintain safe electrical operating conditions.
- E. The operation of the customer's parallel generation system must be approved by PW&U Engineering. The metering location, type of metering and the method of inter-connecting

## CHAPTER 8 – ELECTRIC UTILITY

between the customer and PA Light Utility's system, will be designated by PW&U Engineering.

- F. Cogeneration is the joint production of electric energy and useful thermal energy in a combined process. It includes, but is not limited to: gas turbines and diesel-driven generators (with waste heat recovery), and steam or back-pressure turbines. Each proposal for cogeneration will be handled on an individual basis by means of a special contract with the PA Light Utility.
- G. The operation of the customer's cogeneration system is to be approved by PW&U Engineering. The metering location, type of metering, and the method of inter-connecting between the customer and the PA Light Utility system will be designated by PW&U Engineering.

### 8.17 AVAILABLE FAULT CURRENT

- A. Customer must provide service entrance equipment rated to interrupt the amount of fault current available. Contact PW&U Engineering for information on available fault current at the service point. Provide estimated connected load and summary of major electrical loads to ensure an accurate value. Minimum main circuit breaker fault duty rating shall be 10,000 amperes for residential and 20,000 amperes for non-dwelling installations. Higher ratings may be required depending on service size.

### 8.18 OTHER CUSTOMER RESPONSIBILITIES

#### A. CUSTOMER'S RESPONSIBILITY FOR SAFETY

The customer shall comply with all Federal, State and local laws and regulations as well as all applicable laws of negligence concerning all activities in the vicinity of PA Light Utility electrical wire lines and equipment, whether on customer premises or used to deliver electricity from the generating facilities to his premises. The customer shall comply with laws and regulations to protect himself, his family, his employees, PA Light Utility, and all third parties from injury, loss or damage. If the PA Light Utility serves the customer by means of primary voltage or transmission voltage circuits to the customer's premises, the PA Light Utility may require the customer to obtain and retain insurance coverage which the PA Light Utility deems adequate to satisfy the duty of indemnification.

#### B. RIGHTS-OF-WAY

The customer shall provide, without cost to the PA Light Utility, all rights-of-way and easements required for the installation of facilities necessary or convenient for the supplying of electric service and free access at reasonable times to customer's premises for all work necessary to maintain continuity of such service.

#### C. CLEARANCES

- 1. Clearances to PA Light Utility equipment are governed by the Washington Administrative Code, Port Angeles Municipal Code, and the National Electrical Safety Code. Generally, the horizontal clearance from a pad-mounted transformer or power pole to the surface of a flammable structure shall not be less than 10 (ten) feet. Contact PW&U Engineering for details and specifics on these

## CHAPTER 8 – ELECTRIC UTILITY

and other devices. See details in Appendix B for some standard clearance requirements.

2. Clearance from any structure or sign to a primary voltage conductor shall be at least 12 feet 6 inches, per Municipal Code Title 14.05.200.
3. Clearances between overhead conductors and trees are the responsibility of the tree owner. For trees on private property, PA Light Utility will de-energize overhead secondary services, and re-energize at no cost, where required to safely facilitate the trimming of trees. Trimming is the responsibility of the property owner. PA Light Utility will trim trees only in public right-of-ways.

### D. FIRE ALARM

1. All new single family residences or duplexes in new subdivisions located outside the four minute Fire Department response zone shall be equipped with residential sprinkler systems. Refer to Municipal Code Title 18.08.110. All new single family residences or duplexes located outside the four-minute response zone, and not in a new subdivision, shall have the option of:
  - a. Installing a residential sprinkler system; and/or
  - b. Installing an outside alarm bell connected to hard-wired smoke detectors with battery back-up. Detectors shall be interconnected, and sprinkler bell shall sound with either or both.

### 8.19 STREET AND AREA LIGHTING

- A. Street lights are intended for traffic safety. Street lighting luminaires shall be provided by developers in subdivisions at locations directed by the City Engineer. Additional lighting at locations not required for traffic safety may be provided upon request if approved by the City Engineer.
- B. All poles and luminaires shall comply with PW&U Engineering material standards. Use of decorative or other special fixtures on public rights-of-way must be coordinated with and approved by PW&U Engineering. Non-standard fixtures will not be maintained by the City. Monthly charges will apply for luminaires not in approved locations, and energy charges will be billed to the Customer to supply non-standard luminaire types.
- C. A developer wishing to install PA Light Utility standard decorative fixtures on non-standard poles will be required to provide spare poles to the City for future use as replacements. The quantity of such poles will be based on a percentage of the number of luminaires initially installed on the site.
- D. Area lighting fixtures are available for use on private property at flat monthly rates that include installation, electricity, and maintenance by the PA Light Utility. Contact PW&U Engineering for details.

**- End of Chapter**

# CHAPTER 8 – ELECTRIC UTILITY

## APPENDICES

### A. ELECTRICAL SERVICE INFORMATION FORM

### B. STANDARD DRAWINGS AND DETAILS

FIGURE 1:	Temporary Service – Underground Single Phase
FIGURE 2:	Temporary Service – Overhead
FIGURE 3:	Meter Clearances
FIGURE 4:	Overhead Service Entrance Meter/Mast Requirements
FIGURE 5:	Pedestal Mounted Meter/Disconnect for Manufactured Homes
FIGURE 6:	Pedestal Mounted 3-Phase Meter Base
FIGURE 7:	Pedestal Mounted Residential Remote Meter
FIGURE 8:	Remote Secondary Pedestal
FIGURE 9:	Trenching: Primary, Secondary, TV, & Telephone Depth
FIGURE 10:	Typical 200A Service Ready for Hook-Up
FIGURE 11:	Safety Clearances Around Pad Mounted Transformers
FIGURE 12:	Padmount Transformer Access Clearances
FIGURE 13:	Three Phase Transformer Pad and Vault
FIGURE 14:	Utility Pedestals at Padmount Transformer
FIGURE 15:	Underground Service Secondary Riser
FIGURE 16:	Clearance Requirements for Overhead Power Lines



# Electrical Service Information Form

Public Works & Utilities Engineering Department (360) 417-4700

Please complete and return to Public Works Engineering Department

Applicant Information	
Permanent service: Name and address of party responsible for permanent service billing?	Name:
	Street:
	City / State / ZIP:
	Daytime Phone: Home Phone:
Contact Information (if other than above)	
Site contact:	Name: Title:
	Daytime Phone:
Contractor:	Name: Company:
	Daytime Phone:
Electrician:	Name: Company:
	Daytime Phone:
Excavator:	Name: Company:
	Daytime Phone:
Project Type	
<input type="checkbox"/> Single-family residence <input type="checkbox"/> Multi-family residence; # of units _____ <input type="checkbox"/> Commercial <input type="checkbox"/> Subdivision; # of lots _____ <input type="checkbox"/> Overhead service <input type="checkbox"/> General service <input type="checkbox"/> Underground service <input type="checkbox"/> Other: _____	
Project Information	
Street address / lot number:	
Nearest cross street:	
Desired connection date:	
Electrical Load	
Total square footage: _____ sq. ft.	Main disconnect size: _____ amps
Voltage:	<input type="checkbox"/> 120/240 1ph <input type="checkbox"/> 120/208 3ph <input type="checkbox"/> 277/480 3ph <input type="checkbox"/> 120/240 3ph <input type="checkbox"/> 480 3W 3ph <input type="checkbox"/> Other _____
	Check all that apply: <input type="checkbox"/> Standard residential loads (Lighting, refrigerator, dishwasher, washer) <input type="checkbox"/> A/C (___ FLA) <input type="checkbox"/> Range/Oven <input type="checkbox"/> Hot Tub <input type="checkbox"/> Clothes Dryer <input type="checkbox"/> Heating <input type="checkbox"/> Pumps (___ Hp) <input type="checkbox"/> Water Heater <input type="checkbox"/> Elevator (___ Hp) <input type="checkbox"/> Other _____
Supporting	
Please provide a copy of the following: *Detailed plot plan (.dwg or .dxf format mandatory for subdivisions). *Electrical one-line drawing showing the service entrance panel and location. *Connected load data. *Size and locked rotor amps of all motors over 50hp.	
Applicant's Signature:	Date:

MAIL OR DELIVER COMPLETED FORM TO: 321 E 5TH STREET; PORT ANGELES, WA 98362

FAX TO: 360-417-4709      EMAIL: banders@cityofpa.us (west of Laurel St)

rlarson@cityofpa.us (east of Laurel St)

WS \_\_\_\_\_

**CALL BEFORE YOU DIG**  
1-800-424-5555

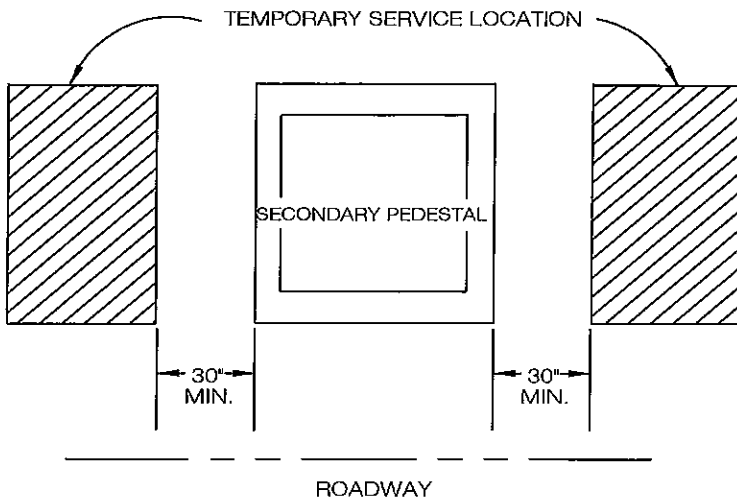

**NOTES:**

Customer to hand-dig trench adjacent to secondary pedestal or transformer.

Temporary service to be 120/240V, 3 wire, with ground.

Install 5/8" x 8 Ft ground rod, galvanized or copper bonded.

Provide GFCI protection per NEC.

**CUSTOMER OWNED AND INSTALLED**

- ① 6"x 6" continuous single post of length to achieve proper meter height.
- ② 2"x 4" bracing – post shall be braced from two directions.
- ③ 2"x 4" stakes
- ④ Meter base and service panel (breaker only) with GFCI protected outlet and weatherproof cover, 60 – 200 amps. 120/240 volts.
- ⑤ Rigid steel or schedule 80 PVC conduit.
- ⑥ Service conductors approved for direct burial.
  - 2 – black phase conductors
  - 1 – white neutral conductor

- ⑦ #6 CU, bare, to ground rod.
- ⑧ Trench and backfill

**UTILITY OWNED AND/OR INSTALLED**

- ① Secondary pedestal or transformer
- ② Electric Meter.

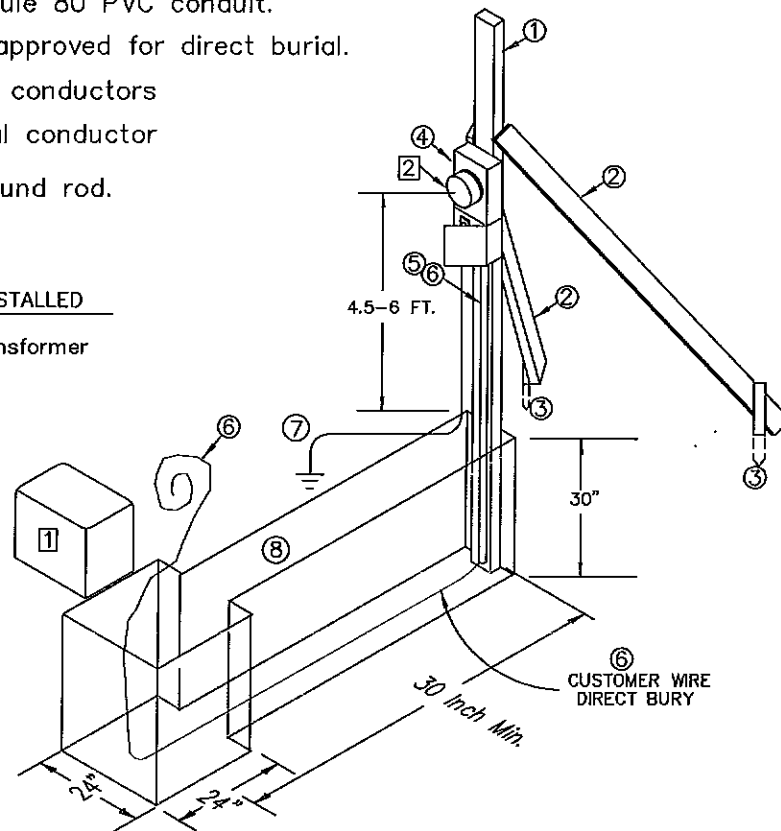

Date: 9/09

City Engr: *[Signature]*  
Elec. Engr: *[Signature]*

**TEMPORARY SERVICE - UNDERGROUND  
SINGLE PHASE - 120/240V**

CITY OF PORT ANGELES  
ELECTRICAL ENGINEERING SPECIFICATION

**FIGURE**

**1**

Align braces so that wire will bisect the angle between them.

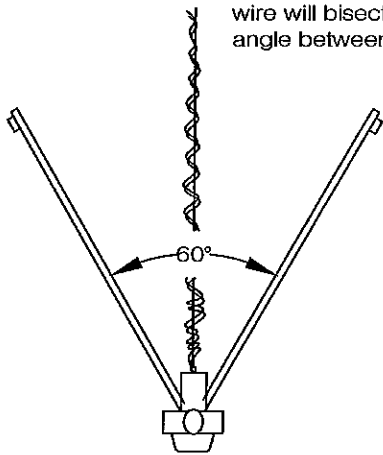

TOP VIEW

CUSTOMER OWNED AND INSTALLED

- ① Service Pole 4" x 6" minimum.
- ② Pole brace (2 required) 2" x 4" minimum.
- ③ Brace stakes (2 required) 2" x 4" minimum.
- ④ Electrical conduit.
- ⑤ Weatherhead.
- ⑥ Insulated knob.
- ⑦ Meterbase and service panel (breaker only) with GFCI protected outlet and weatherproof cover-100-200amps 120/240volts.
- ⑧ #6cu ground wire.
- ⑨ 5/8" x 8' ground rod.

PORT ANGELES CITY LIGHT OWNED AND/OR INSTALLED

- ① Overhead service wires
- ② Electrical meter.

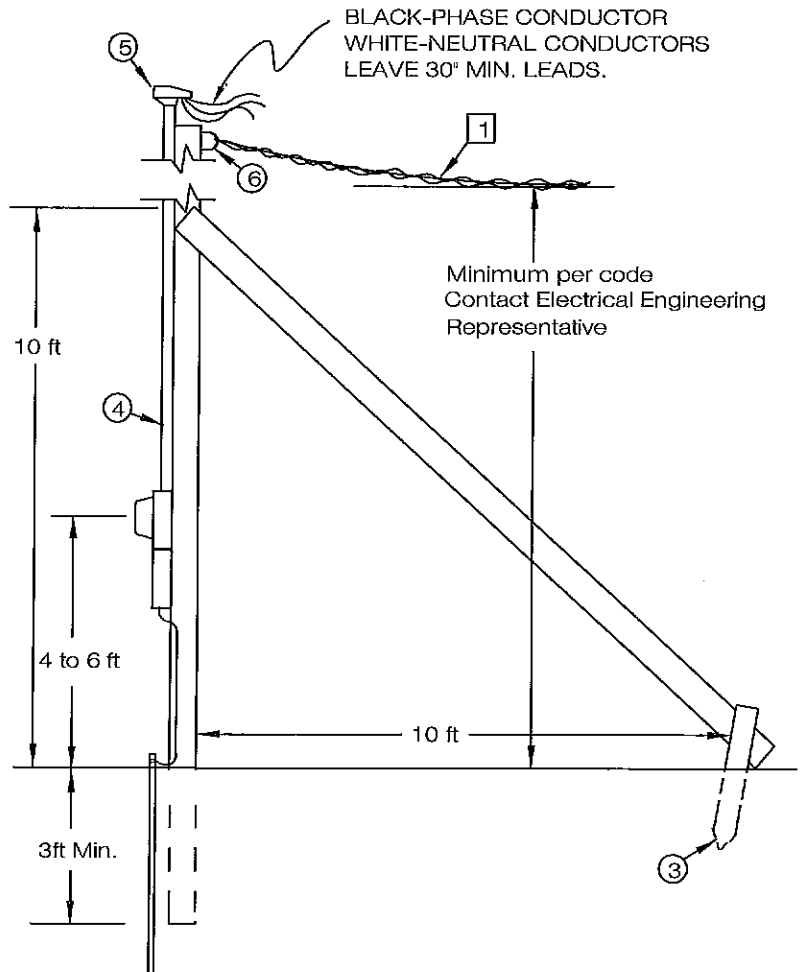
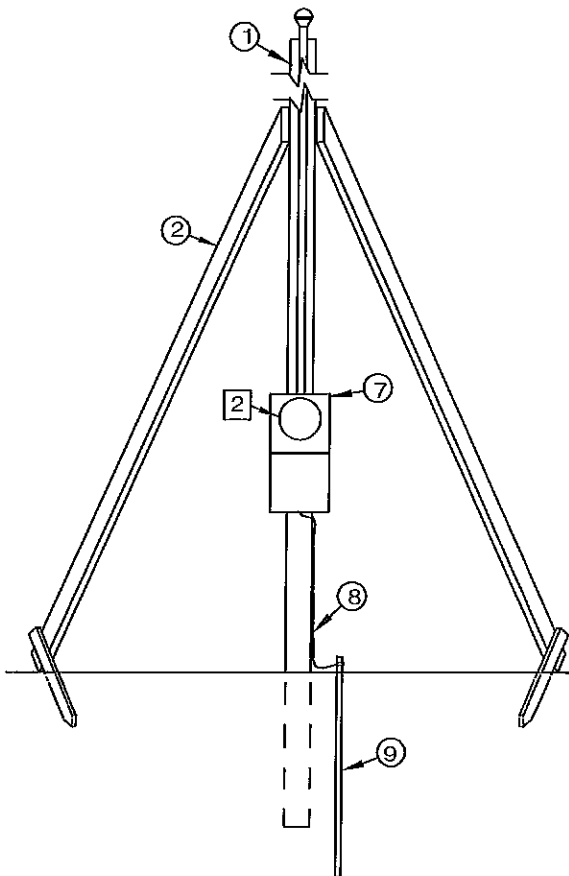

Date: 9/09

City Eng:  
Elec. Eng.

*[Signature]*  
170

TEMPORARY SERVICE - OVERHEAD

CITY OF PORT ANGELES  
ELECTRICAL ENGINEERING SPECIFICATION

FIGURE

2

ALL HEIGHTS ARE MEASURED FROM THE STANDING SURFACE TO THE CENTERLINE OF THE METER

The minimum height of the center of the meter shall not be less than four feet-six inches (4'-6"), and the maximum height shall not exceed six feet (6'-0") above final grade or finished floor. The desired height is five feet (5') above final grade or finished floor.

When pedestals are used, the minimum height of the center of the meter shall be thirty-six (36") from the top of the pad or finished floor. The maximum height shall be forty-eight inches (4'-0").

#### WORKING SPACE

To permit access to the metering installations and to provide safety for personnel, a working and standing space entirely on the Customer's property shall be provided in front of all meter socket(s). All clearances shall be at least the minimums shown below. Total height for working clearances shall be no less than six feet six inches (6'-6").

#### BARRICADES

The Customer shall furnish, install, and maintain, or make a contribution in aid of construction to the City for permanent barricades to provide protection where the working space is exposed to vehicles or hazardous conditions. The determination of need, type, size, and location of barricades is at the sole discretion of the City.

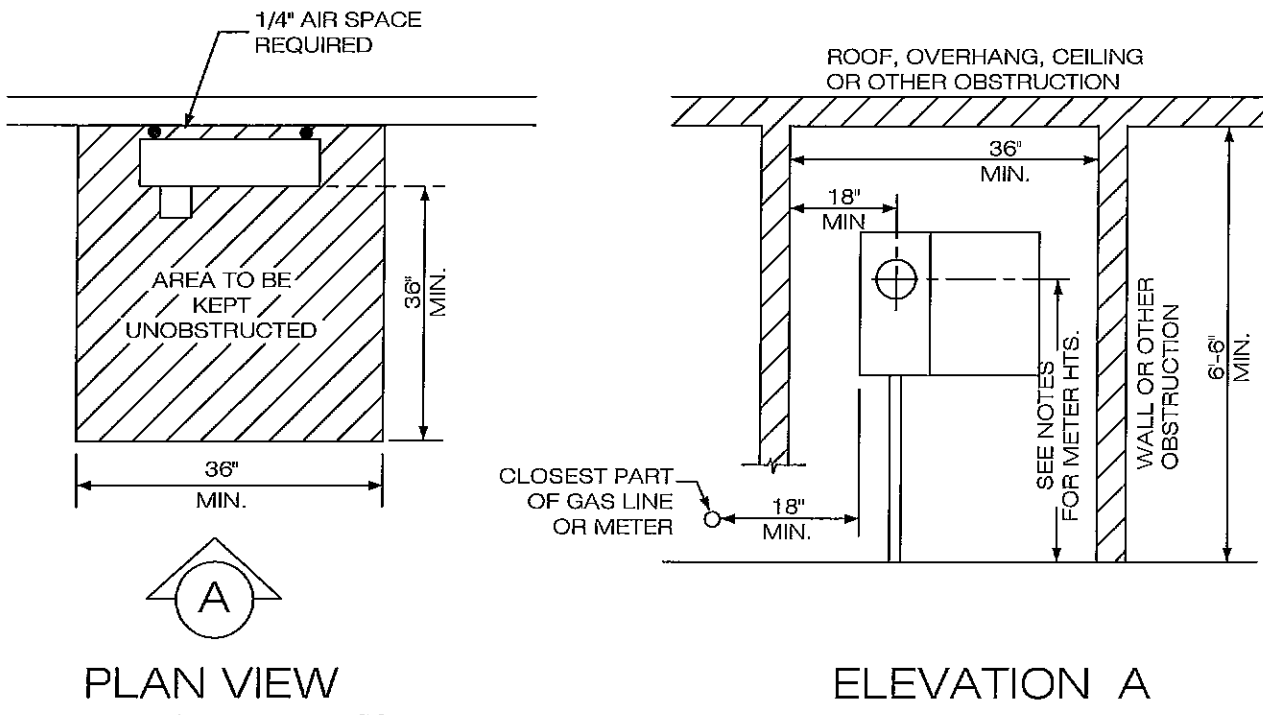

Date: 9/09  
City Engr: *[Signature]*  
Elec. Engr: *[Signature]*

## METER CLEARANCES

CITY OF PORT ANGELES  
ELECTRICAL ENGINEERING SPECIFICATION

FIGURE  
3

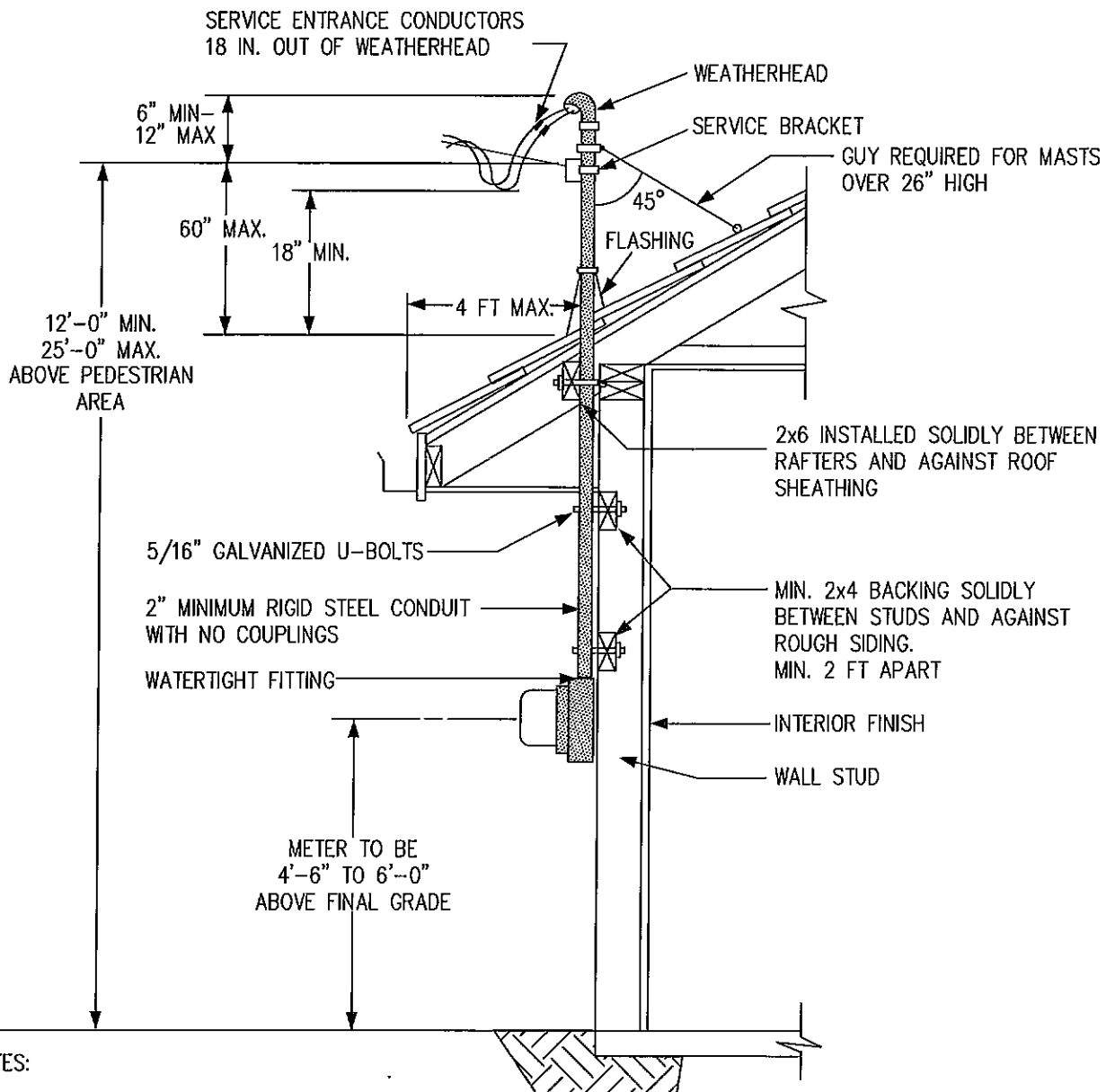

NOTES:

Masts must be braced, secured, and supported in such a manner that no pressure from the attached conductors will be exerted on a roof flashing, meter base, or other enclosures.

Couplings may only be used below the point where the mast is braced, secured, or supported. There must be two means of support above any coupling used.

Service mast support guys must be installed if the service drop attaches to the mast more than 26 inches above the roof line, or if the service drop is greater than 75 feet in length from the supply pole.

Alternate mast supports of equal strength may be used for altered services on existing buildings where it is not practical to install blocking in walls for U-bolt support.



Date: 9/09  
City Engr.  
Elec. Engr.

OVERHEAD SERVICE ENTRANCE  
METER/MAST REQUIREMENTS  
CITY OF PORT ANGELES  
ELECTRICAL ENGINEERING SPECIFICATION

FIGURE  
4

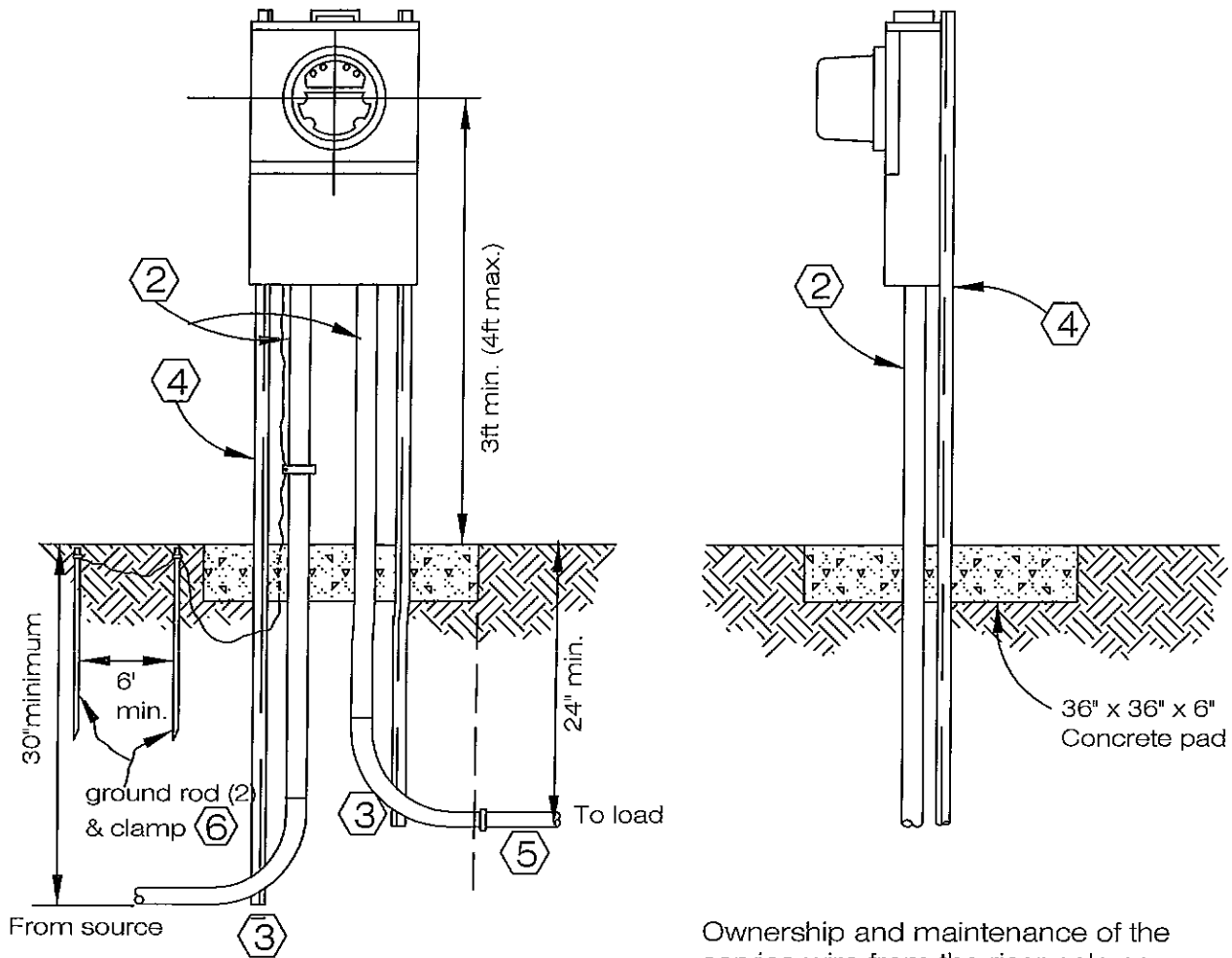

Ownership and maintenance of the service wire from the riser pole or secondary pedestal to the home is the owners responsibility.

- ① Location: Maximum 5 feet from mobile, modular, or premanufactured home.
- ② Schedule 80 PVC above ground to 2 feet below grade.
- ③ Schedule 40 PVC.
- ④ UL approved manufactured pedestal, or 1" x 4" galvanized channel iron, to bottom of ditch, or 2-5 foot pieces of galvanized steel strut (hole less) minimum of 18 inches in ground. Mount on 36" x 36" x 6" minimum concrete pad.
- ⑤ The City requires that all wire be placed in conduit for future maintenance.
- ⑥ Approved ground rods (2) and clamps, flush with grade.



Date: 9/09

City Engr

Elec. Engr.

PEDESTAL MOUNTED METER/DISCONNECT  
FOR MOBILE, MODULAR, AND PREMANUFACTURED HOMES  
CITY OF PORT ANGELES  
ELECTRICAL ENGINEERING SPECIFICATION

FIGURE

5

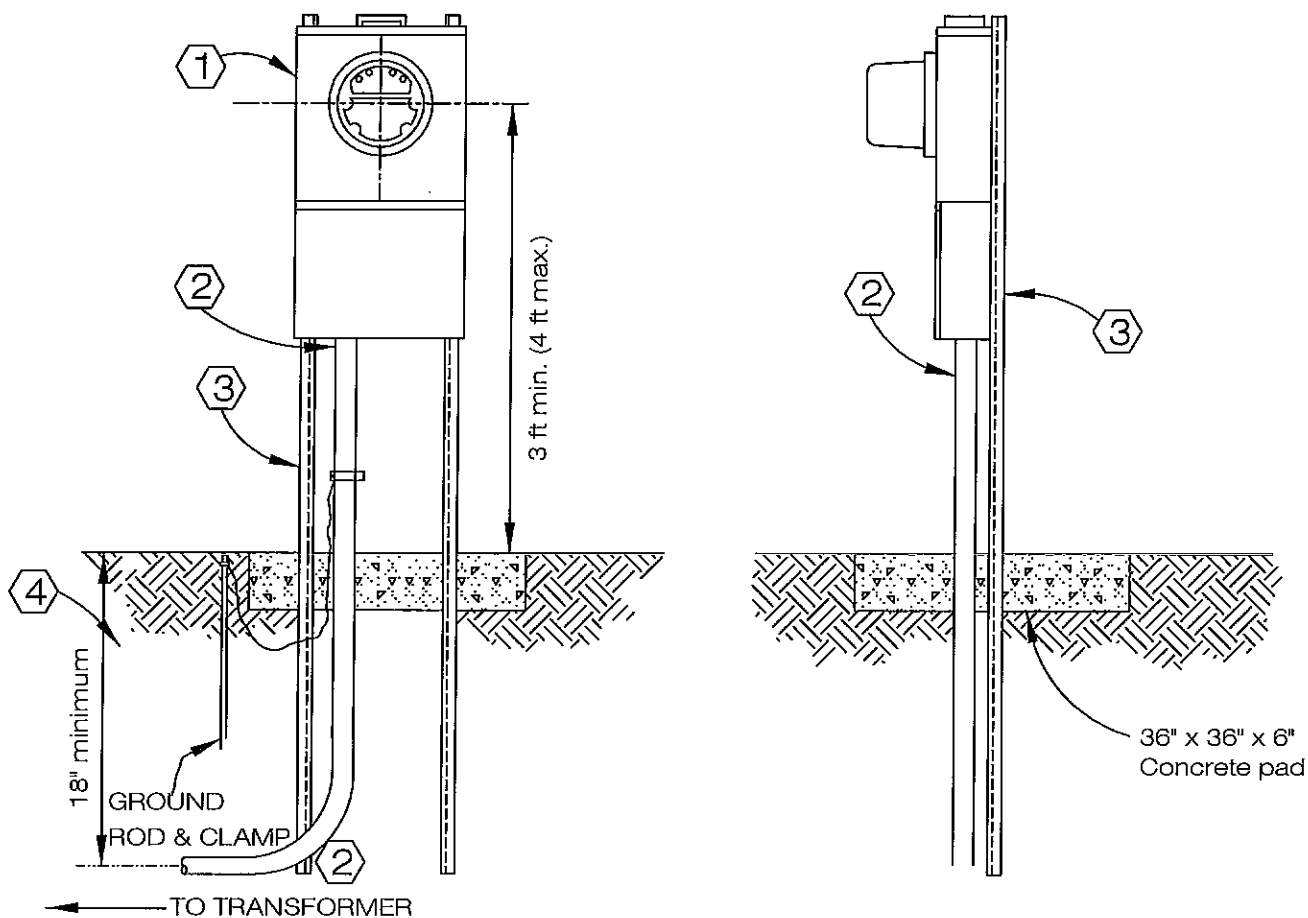

- ① Meterbase, CT rated, 13 terminal, MILBANK CAT. NO. UC 3433-XL or equal with room for a test switch.
- ② 1-inch rigid steel conduit to current transformer cabinet.
- ③ Galvanized strut to bottom of trench.  
Mount on 36" x 36" x 6" minimum concrete pad.
- ④ Approved 8 ft x 5/8" ground rod & clamp (2).

Location: To be determined by Port Angeles Public Works & Utilities.



Date: 9/09

City Eng.  
Elec. Eng.

### PEDESTAL MOUNTED 3 PHASE INSTRUMENT METERBASE

CITY OF PORT ANGELES  
ELECTRICAL ENGINEERING SPECIFICATION

FIGURE

6

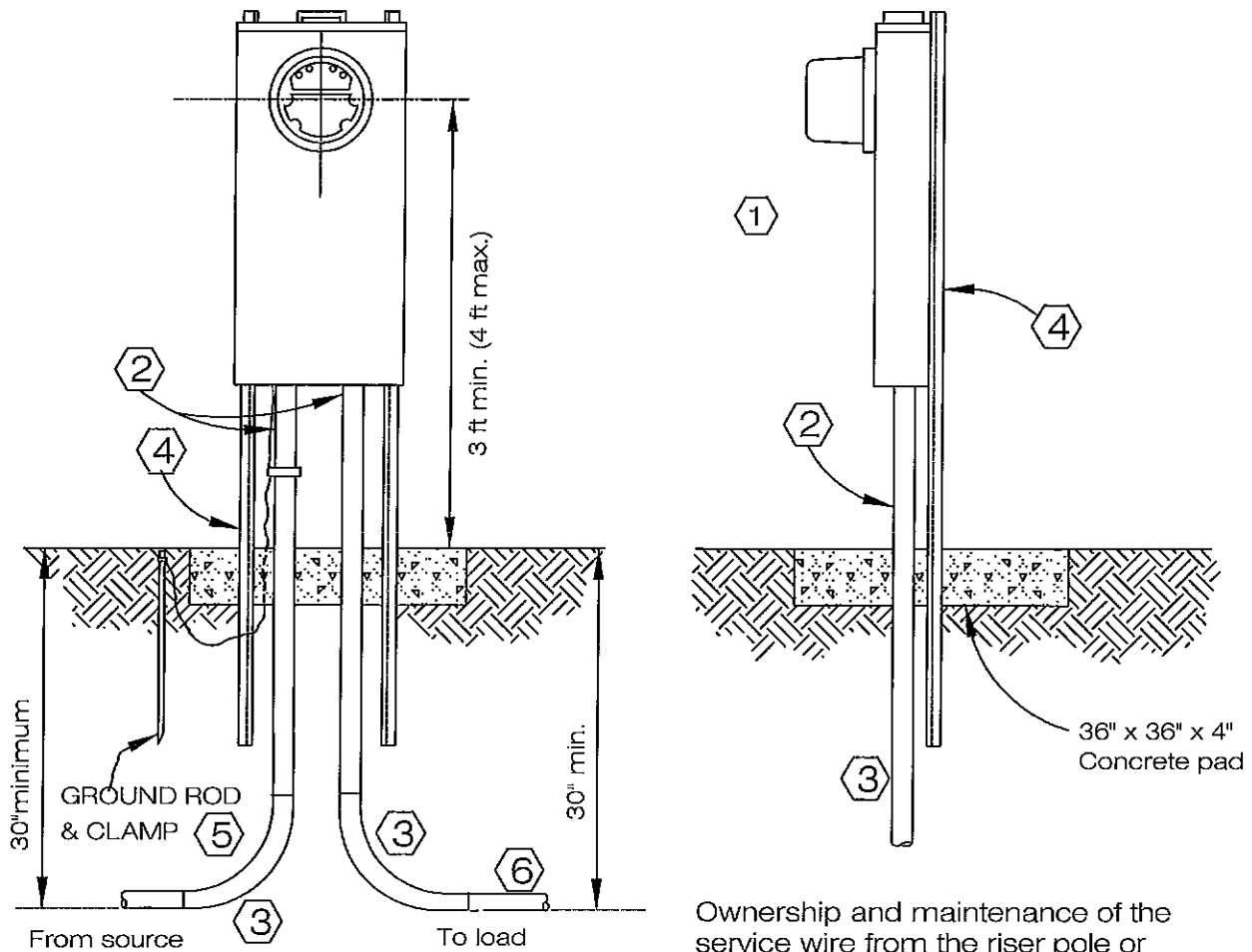

Ownership and maintenance of the service wire from the riser pole or secondary pedestal to the home is the owners responsibility.

- ① Maintain minimum working clearance in front of meter of 36"W x 36"D x 78"H.
- ② Rigid steel conduit or schedule 80 PVC above ground to 24" below final grade.
- ③ Schedule 40 PVC underground.
- ④ U.L. approved meterbase. 1" x 4" galvanized channel iron, or 2-5 ft x 1½" pieces of galvanized strut minimum of 18" in ground. Mount on 36" x 36" x 4" minimum concrete pad.
- ⑤ Approved 8 ft ground rod and clamp driven flush with grade.
- ⑥ The City requires that all wire be placed in conduit for future maintenance.

**PEDESTAL MOUNTED  
RESIDENTIAL REMOTE METER**  
CITY OF PORT ANGELES  
ELECTRICAL ENGINEERING SPECIFICATION

**FIGURE  
7**



Date: 9/09

City Engr:  
Elec. Engr:

*[Handwritten signatures]*

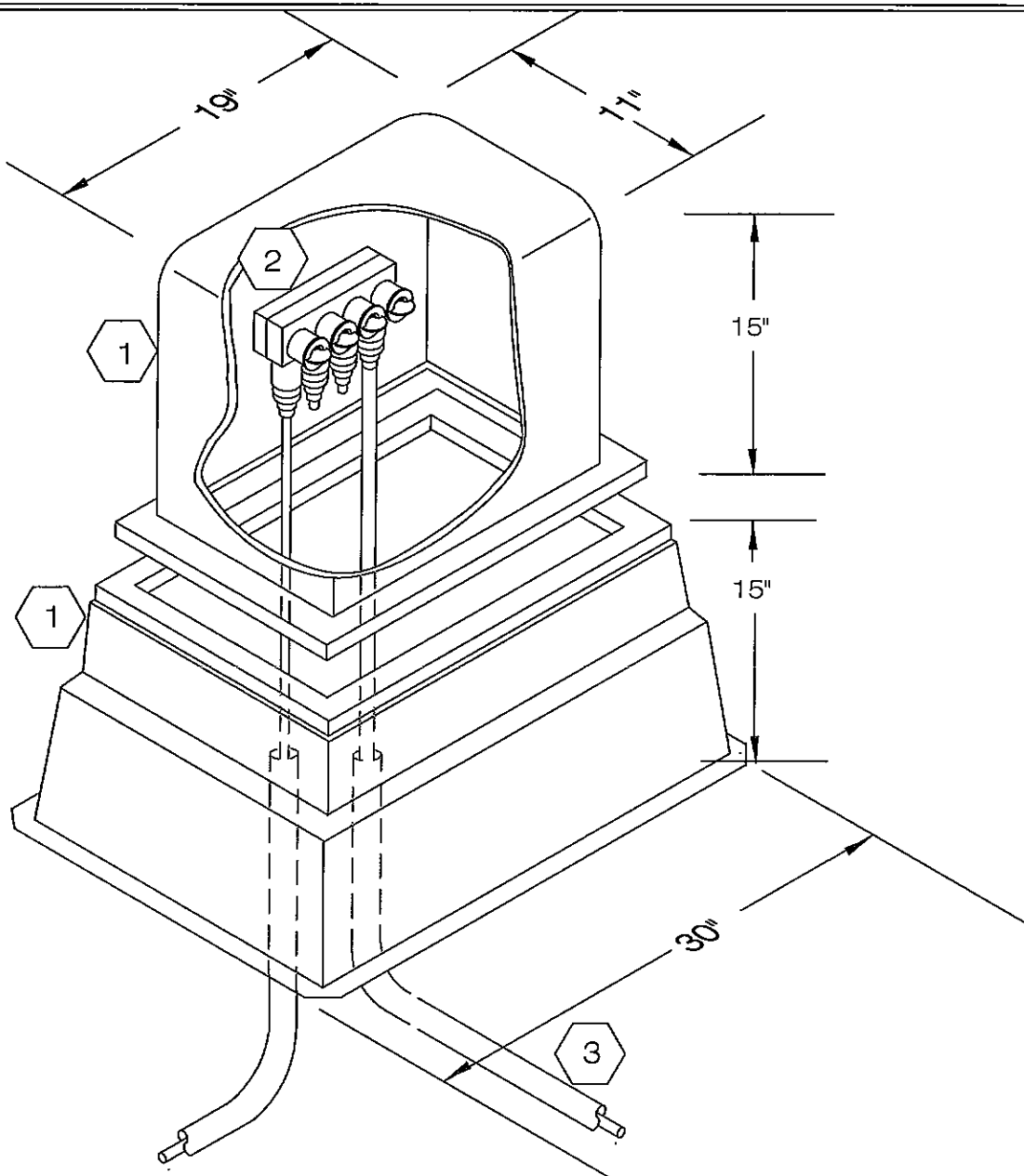

ITEM	QUANTITY	STOCK No.
1. Secondary Pedestal, FG	1	285 099 00004
2. Connector bar, Flood Seal Rubberized Al	3	285 097 00069
3. PVC, sch 40, 3"	as required	285 019 00003



Date: 9/09

City Engr:  
Elec. Engr:

*[Handwritten signature]*  
*[Handwritten initials]*

## REMOTE SECONDARY PEDESTAL

CITY OF PORT ANGELES  
ELECTRICAL ENGINEERING SPECIFICATION

FIGURE

8

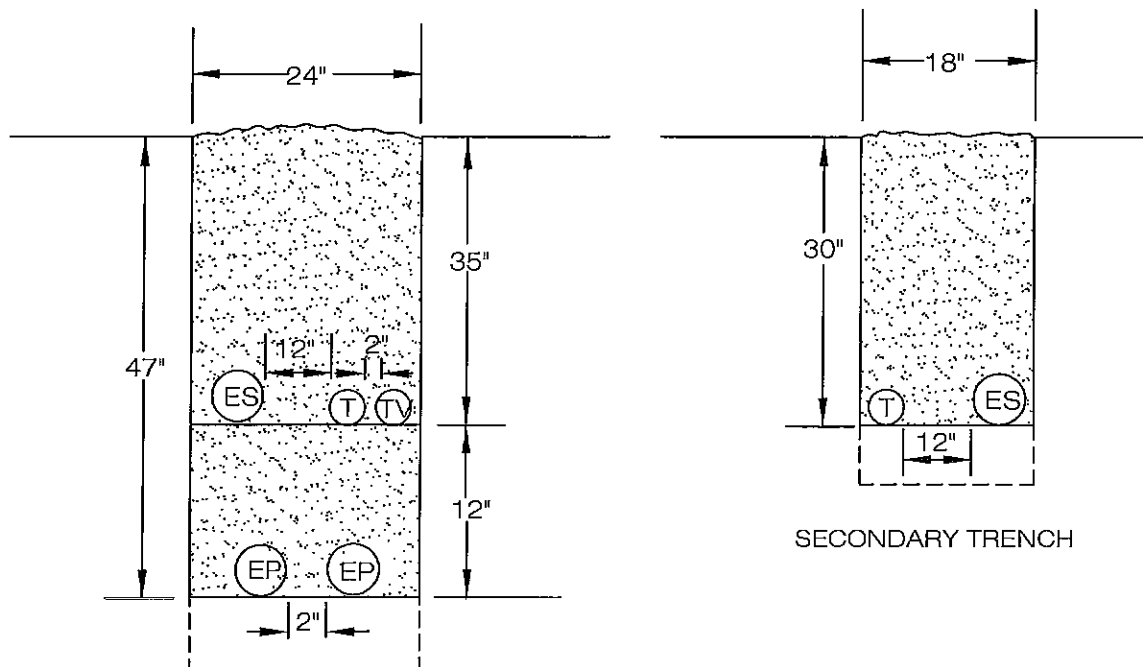

TRENCH NOTES

1. THE CUSTOMER IS RESPONSIBLE FOR DIGGING, BACKFILLING, AND COMPACTING TRENCHES.
2. ALL DIMENSIONS SHOWN ARE RELATIVE TO FINAL GRADE. ALL COVERAGE DEPTHS AND SPACING DIMENTIONS ARE MINIMUMS.
3. TO THE EXTENT POSSIBLE, TRENCHES SHALL BE STRAIGHT LINES.
4. THE BOTTOM OF THE TRENCH AND BACKFILL WITHIN 6 INCHES OF ELECTRICAL CONDUIT SHALL BE FREE OF ROCKS LARGER THAN 1.5 INCHES, DEBRIS, PAVING MATERIAL, SHARP ANGULAR OBJECTS, OR CORROSIVE MATERIALS THAT MAY DAMAGE THE CONDUIT OR PREVENT ADEQUATE COMPACTION OF BACKFILL. IF TRENCH BOTTOM CONTAINS ROCKS EXCEEDNG THIS LIMIT, THE TRENCH SHALL BE OVEREXCAVATED BY 6 INCHES AND THEN BEDDED WITH 6 INCHES OF ACCEPTABLE MATERIAL, AND COMPACTED PRIOR TO INSTALLING THE CONDUIT.
5. KEEP THE SPOILS PILE AT LEAST 24 INCHES AWAY FROM THE EDGE OF THE TRENCH.
6. MINIMUM COVER AND TRENCH DEPTH REQUIREMENTS SHALL BE INCREASED BY 12 INCHES AT UNDEVELOPED LOCATIONS WITHOUT FINAL GRADE STAKES. CUSTOMER OR DEVELOPER IS RESPONSIBLE FOR PROVIDING FINAL GRADE, AND WILL BE RESPONSIBLE FOR ANY COSTS ASSOCIATED WITH RELOCATION OF UNDERGROUND FACILITIES DUE TO SUBSEQUENT GRADE CHANGE.
7. TRENCHES 48 INCHES OR MORE IN DEPTH INTO WHICH A WORKER MUST ENTER SHALL HAVE ADEQUATE PROTECTION PROVIDED PER WAC 296-155.
8. TO ALLOW FOR ADEQUATE COMPACTION, ALL CONDUIT SHALL BE INSTALLED A MINIMUM OF 1 INCH FROM THE SIDES OF THE TRENCH.
9. CONTROLLED DENSITY BACKFILL IS REQUIRED UNDER ALL PAVED STREET SURFACES.
10. ALL ELECTRICAL TRENCHES MUST BE INSPECTED AND APPROVED BY PW&U LIGHT OPERATIONS PRIOR TO BACKFILLING.
11. SCHEDULE TRENCHING SO THE TRENCH IS OPEN FOR THE SHORTEST PRACTICAL TIME TO AVOID CREATING A PUBLIC HAZARD, AND TO MINIMIZE THE POSSIBILITY OF THE TRENCH COLLAPSING DUE TO OTHER CONSTRUCTION ACTIVITY, RAIN, ETC.

LEGEND

- ES - ELECTRIC SECONDARY
- EP - ELECTRIC PRIMARY
- T - COMMUNICATIONS
- TV - CABLE TV



Date: 9/09

City Engr:

Elec. Engr:

*[Handwritten signature]*

TRENCHING: PRIMARY, SECONDARY,  
TV, & TELCO DEPTH

CITY OF PORT ANGELES  
ELECTRICAL ENGINEERING SPECIFICATION

FIGURE

9

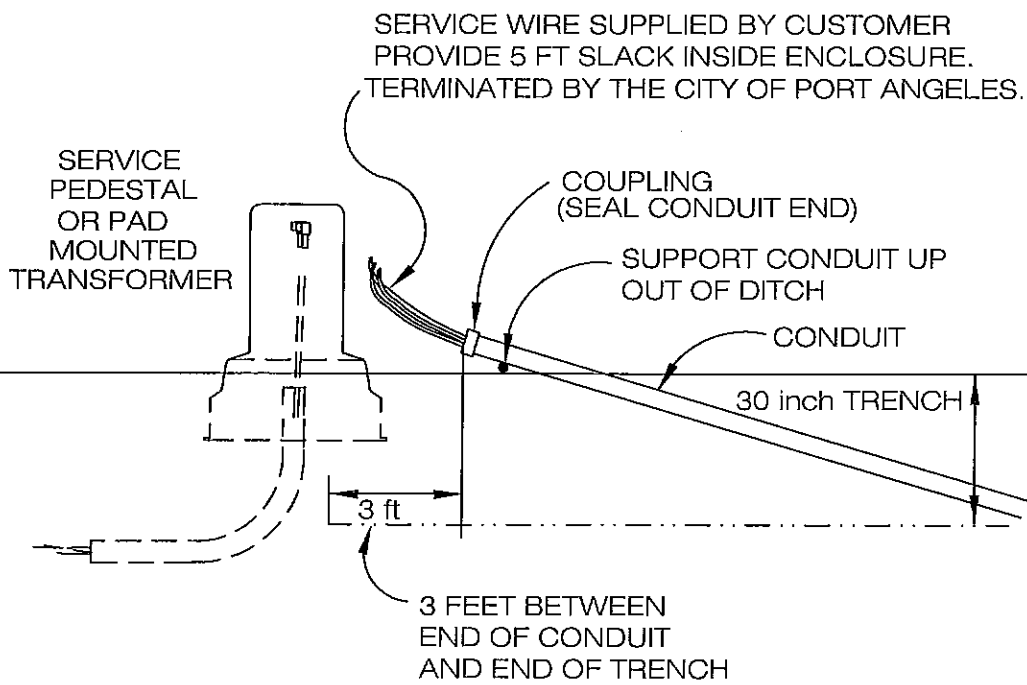

CUSTOMER MUST CONTACT CITY FOR  
ELECTRICAL INSPECTION BEFORE CITY CREWS  
WILL INSTALL CONDUIT INTO PEDESTAL OR  
TRANSFORMER.



Date: 9/09  
City Engr:  
*[Signature]*  
Elec. Engr.

TYPICAL 200A SERVICE  
READY FOR HOOK-UP  
CITY OF PORT ANGELES  
ELECTRICAL ENGINEERING SPECIFICATION

FIGURE  
10

NOTE:

- ① 3 FT. MINIMUM CLEARANCE TO NON-COMBUSTIBLE SURFACES ON BACK AND SIDES, 10 FT. TO COMBUSTIBLE SURFACES.

10 FT CLEAR SPACE IS ALWAYS REQUIRED IN FRONT OF A TRANSFORMER.

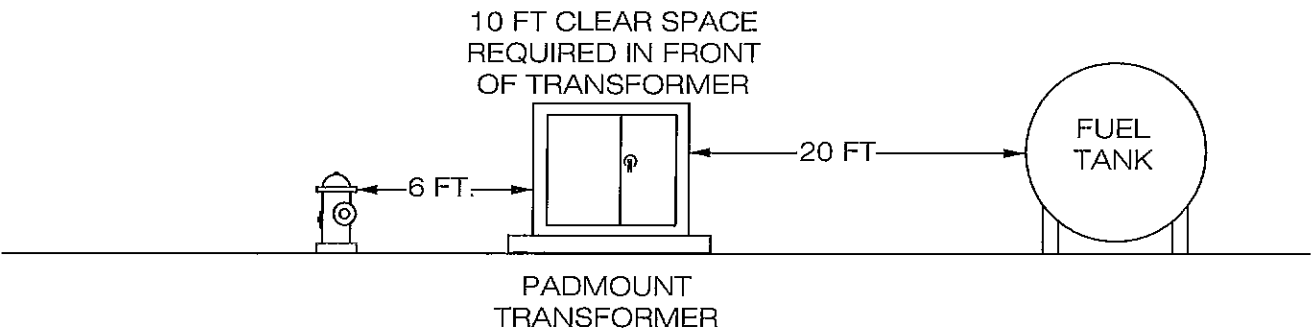
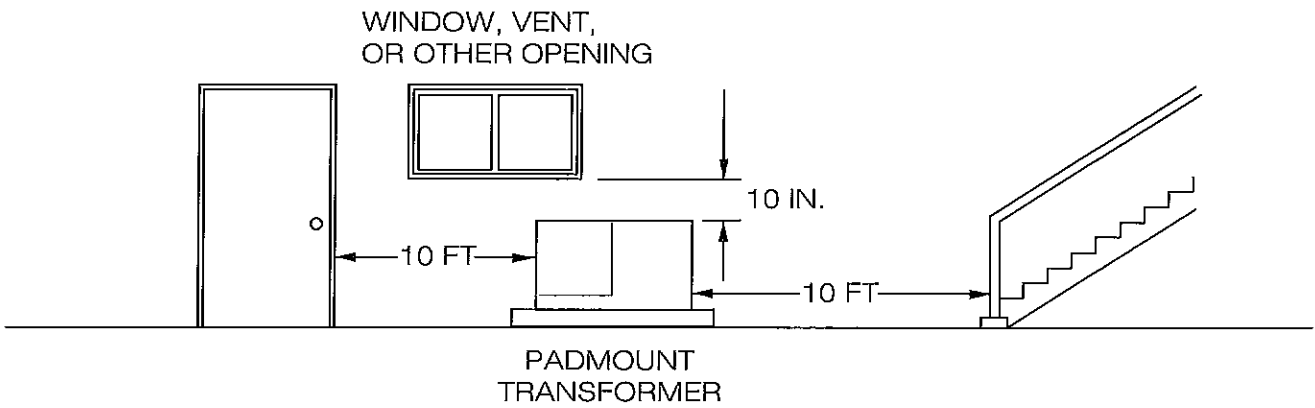
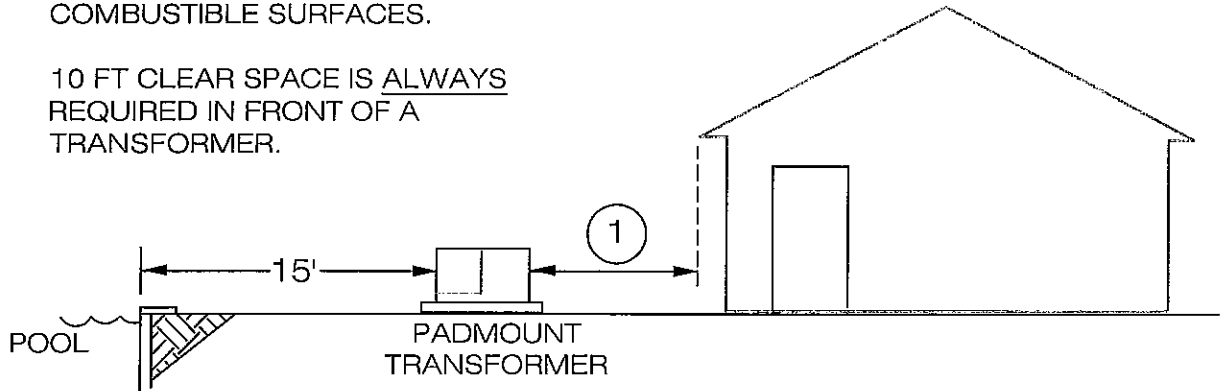

NOT TO SCALE



Date: 9/09  
City Engr: *[Signature]*  
Elec. Engr: *[Signature]*

**SAFETY CLEARANCES AROUND  
PAD MOUNTED TRANSFORMERS**  
CITY OF PORT ANGELES  
ELECTRICAL ENGINEERING SPECIFICATION

FIGURE

11

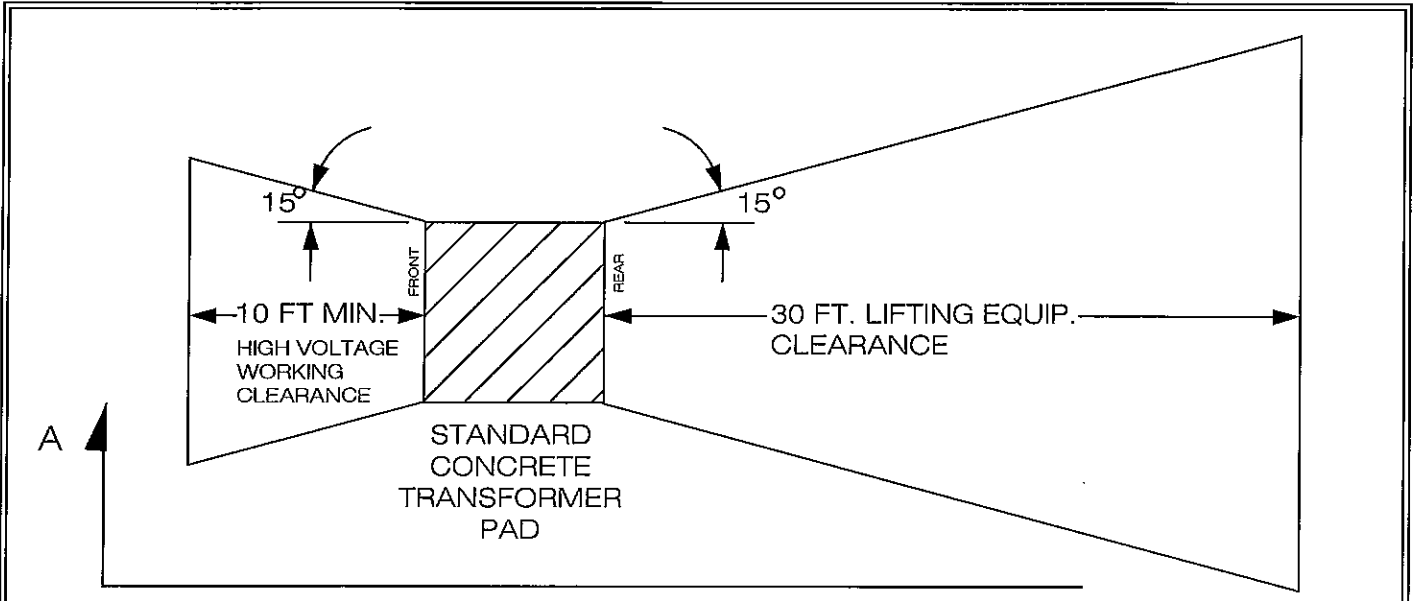

PLAN VIEW

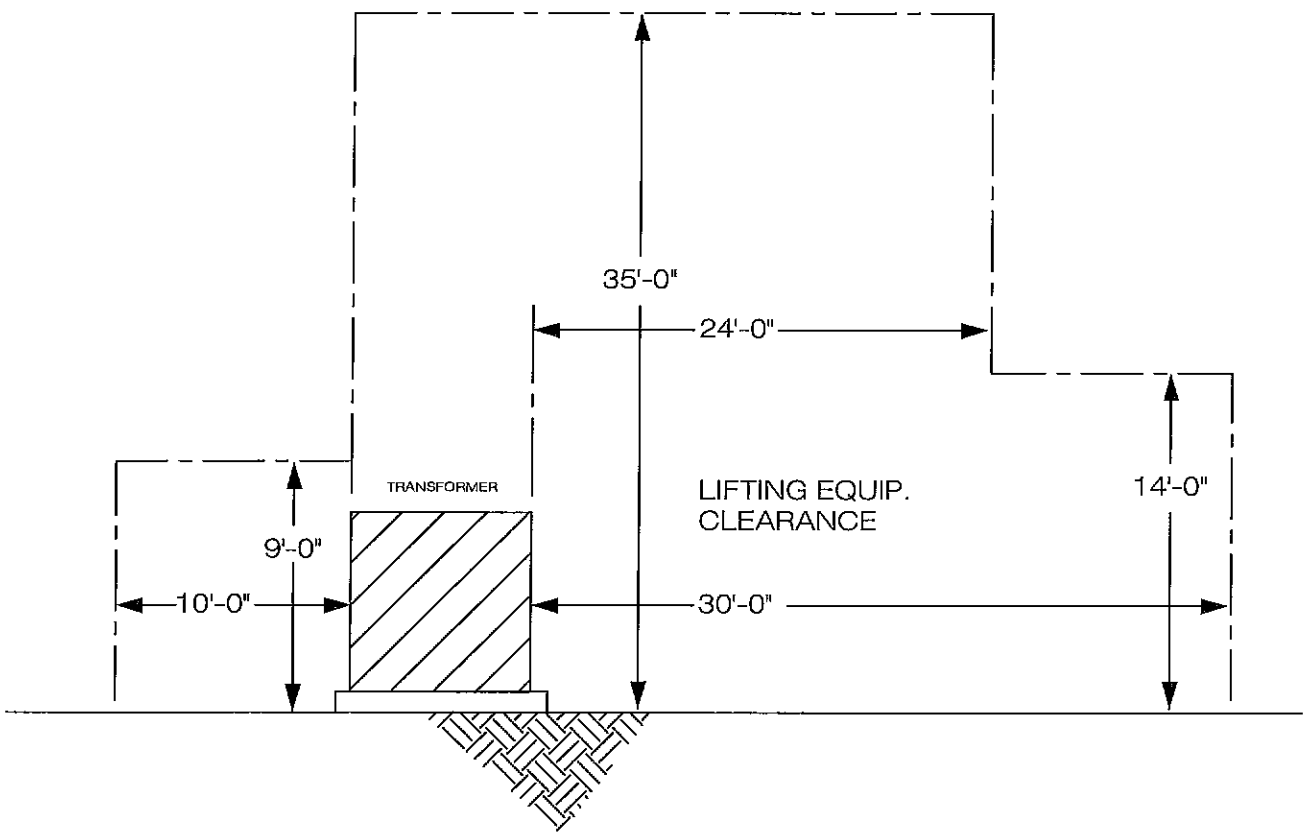

ELEVATION A

NOT TO SCALE

Date: 9/09  
 City Engr: *[Signature]*  
 Elec. Engr: *[Signature]*

**PADMOUNT TRANSFORMER  
 ACCESS CLEARANCES**  
 CITY OF PORT ANGELES  
 ELECTRICAL ENGINEERING SPECIFICATION

**FIGURE**  
 12

ITEM

QUANTITY

STOCK No.

1. Vault 48"x72"x42" with removable divider	1	285 098 00002
2. Transformer Pad 84"x66"x6" with 18" x 50" hole.	1	285 098 00003
3. Conductor, #2 CU bare str. soft drawn	3 ft	280 016 00008
4. Ground rod, 5/8"x 8' , Copper bonded	2	285 074 00022
5. Cadweld, oneshot	2	320 055 00005

CONSTRUCTION NOTES:

1. Grout around conduit
2. Backfill to be mechanically compacted in 6" lifts to 90% maximum Proctor density.
3. Ground to be sloped down and away from the top of the vault.
4. Customer to provide secondary service size.
5. Omit ground rods & cadweld when grounded vault is used.
6. When using ground rods; install 12" to 18" below ground level.
7. Secondary lugs, provided and installed by Public Works Department at the transformer.

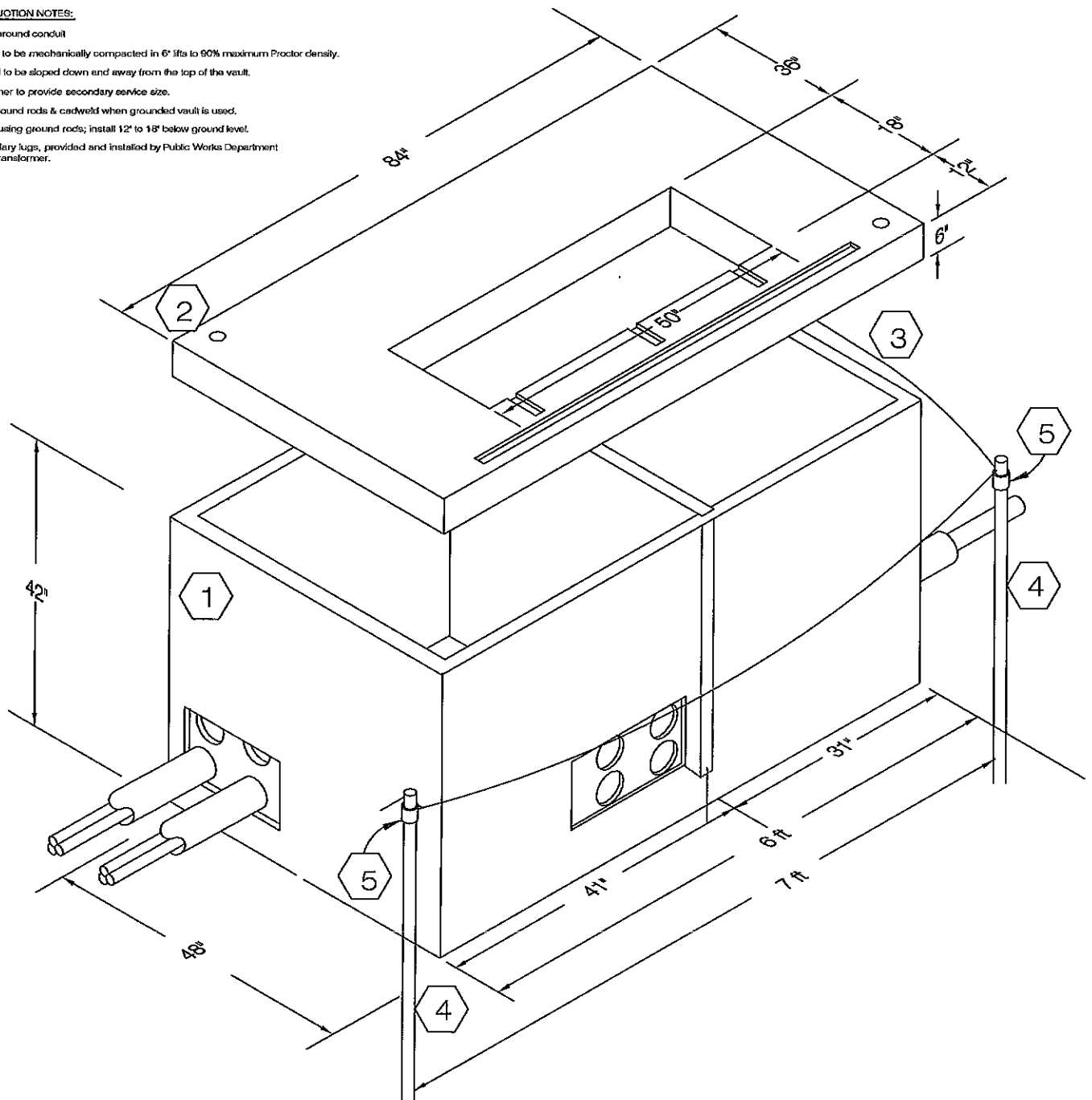

Date: 9/09

City Engr:

Elec. Engr:

### THREE PHASE TRANSFORMER PAD & VAULT

CITY OF PORT ANGELES  
ELECTRICAL ENGINEERING SPECIFICATION

FIGURE

13

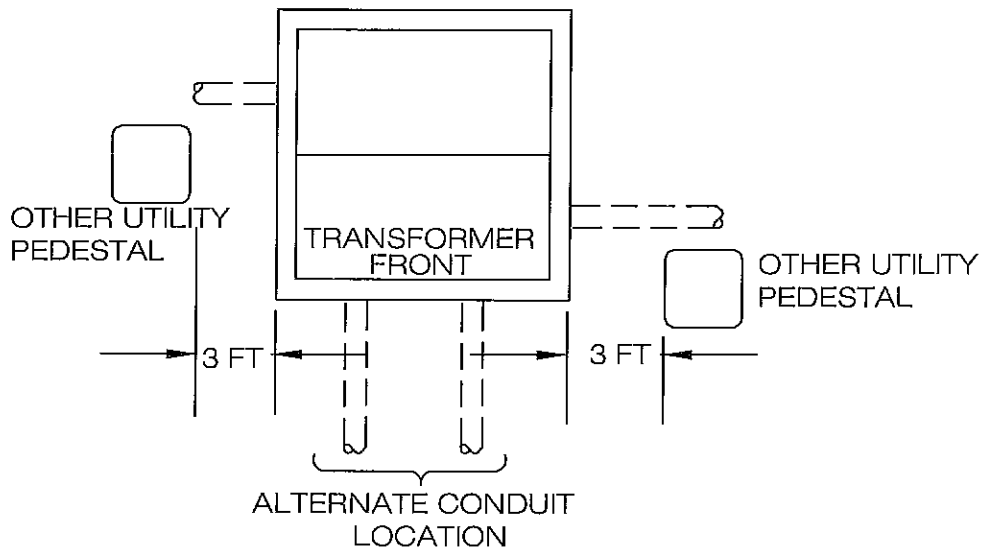

Date: 9/09

City Engr:  
*[Signature]*  
 Elec. Engr:  
*[Signature]*

UTILITY PEDESTALS  
 AT PADMOUNT TRANSFORMER  
 CITY OF PORT ANGELES  
 ELECTRICAL ENGINEERING SPECIFICATION

FIGURE

14

**CUSTOMER:**

- 1) Provide and install rigid steel or schedule 80 PVC conduit from 8 feet above finished grade to 2 feet below grade; schedule 40 conduit in trench to service entrance.
- 2) Provide and install first standoff at or above 8 feet. Provide schedule 40 PVC, weatherhead, and supports to reach within 7 feet of crossarm, for installation by Utility.
- 3) Supply sufficient underground conductor (Type USE or equivalent) to go up length of pole and reach transformer. Provide 3 feet of extra cable for connections.
- 4) Ground metal raceway as required by the NEC.

**UTILITY:**

- 1) Install conduit supports as required.
- 2) Install conduit from 8 feet to within 7 feet of crossarm.
- 3) Connect all conductors at crossarm or transformer.

**NOTE:**

Premanufactured / mobile home on City lot

When a service pole is required to serve a premanufactured or mobile home, it will be located on the customer's property, at the customer's expense, adjacent to the alley or street served by the utility. Underground conductors (no overhead allowed) from this pole to a pedestal mounted meter will provide power to the dwelling.

STUB CONDUIT ON SIDE  
AWAY FROM TRAFFIC

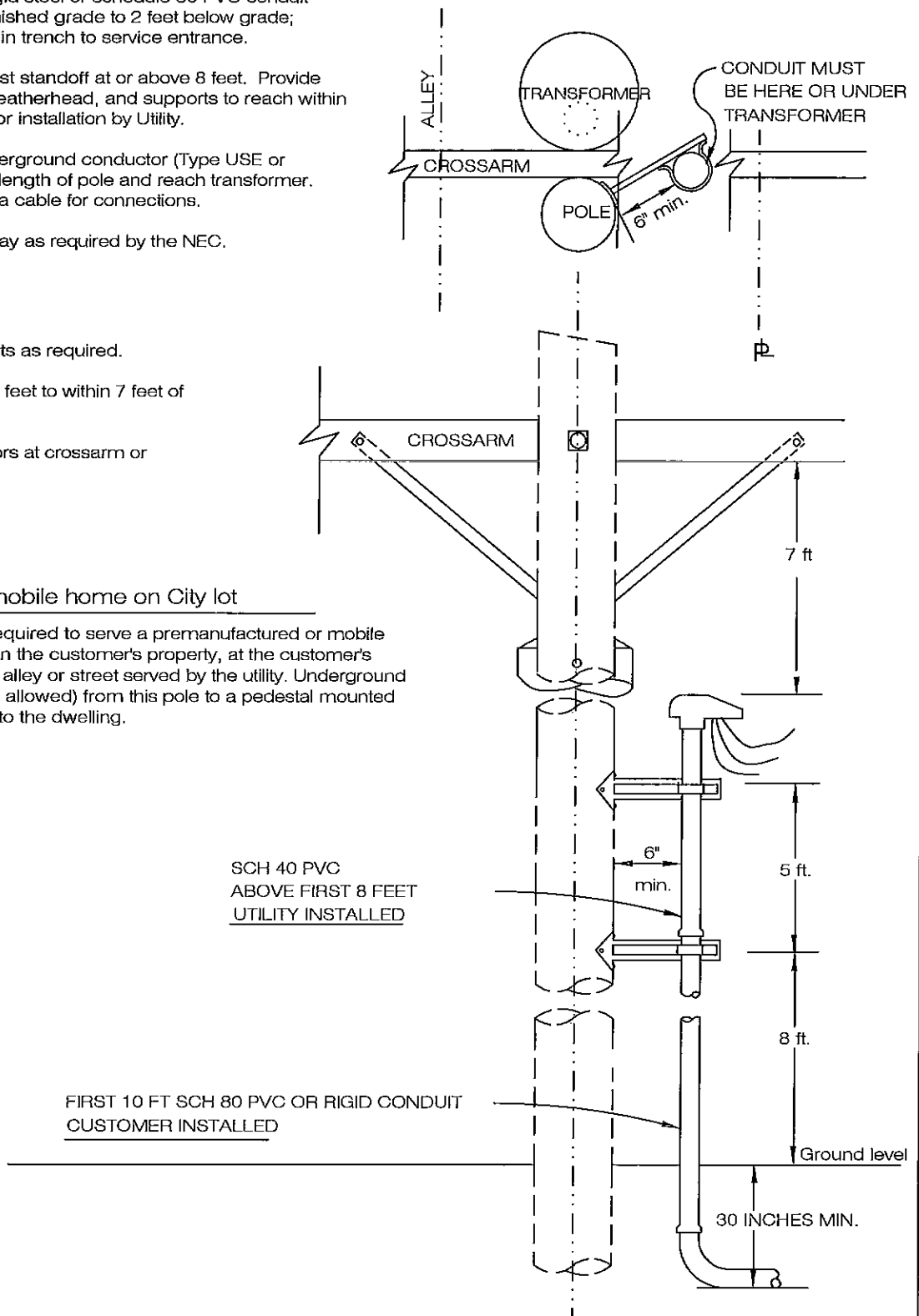

SCH 40 PVC  
ABOVE FIRST 8 FEET  
UTILITY INSTALLED

FIRST 10 FT SCH 80 PVC OR RIGID CONDUIT  
CUSTOMER INSTALLED



Date: 9/09

City Engr:  
Eled. Engr:

*[Handwritten signature]*

**UNDERGROUND SERVICE  
SECONDARY RISER**

CITY OF PORT ANGELES  
ELECTRICAL ENGINEERING SPECIFICATION

**FIGURE**

**15**

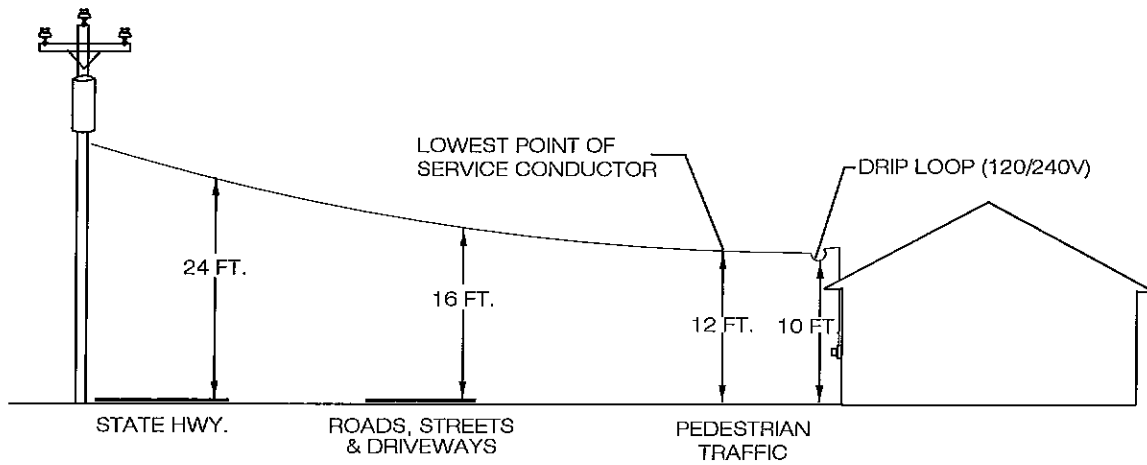

### MINIMUM CLEARANCES FROM GROUND

NOTE:  
ALL DIMENSIONS SHOWN ARE  
MINIMUMS REQUIRED UNDER FULLY  
LOADED CONDITIONS THAT CREATE  
THE LARGEST FINAL SAG.

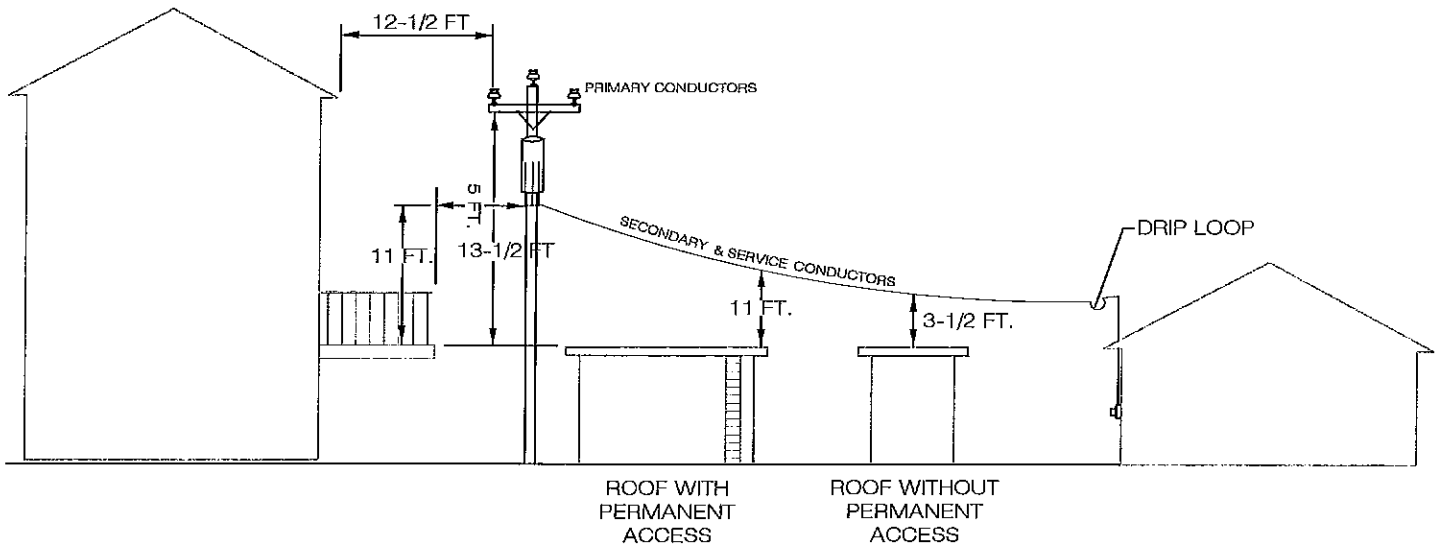

### MINIMUM CLEARANCES TO OTHER STRUCTURES

NOT TO SCALE



Date: 9/09

City Engr:  
*Steph...*  
Elec. Engr.

CLEARANCE REQUIREMENTS FOR  
OVERHEAD POWER LINES  
CITY OF PORT ANGELES  
ELECTRICAL ENGINEERING SPECIFICATION

FIGURE

16