

## CHAPTER 4 – WATER

### "URBAN SERVICES STANDARDS AND GUIDELINES"

CITY OF PORT ANGELES - PUBLIC WORKS & UTILITIES DEPARTMENT

#### 4.01 GENERAL CONSIDERATIONS

- A. Water systems refer to water transmission facilities for domestic, fire protection, commercial and industrial, irrigation, recreation and other uses. Treatment of water shall comply with Washington State Department of Health requirements.
- B. Any extension of the Port Angeles Water System must be approved by the Department of Public Works and Utilities and all extensions must conform to these standards, Washington State Department of Health, the Port Angeles Water System Plan, and the Port Angeles Fire Department requirements. The material contained in this manual shall be used in conjunction with the Washington State Department of Health Regulations and Washington Surveying and Rating Bureau (ISO) regulations to develop all plans and specification and construction of the facilities. Where there are conflicts or differences between these standards and City ordinances, the City ordinances shall apply.
- C. It is the policy of the Public Works and Utilities Department that all parcels within the corporate City limits shall be encouraged to connect to the City water system.
- D. City water service may be provided outside the City. The service area is generally described as within the Port Angeles Urban Growth Area boundary.
- E. In designing and planning for any development, it is the developer's responsibility to see that adequate water for both domestic and fire protection use is attainable. The developer must show, in the proposed plans, how water will be provided, whether the existing system will be adversely impacted, and how adequate water will be supplied at the required pressures in case of fire. A detailed analysis of the system may be required, if it appears that the system might be inadequate.
- F. Anyone that wishes to extend or connect to the City's water system should contact the Department of Public Works and Utilities for the preliminary information and discussion of the extension proposed. The design of a water system extension is the responsibility of the Developer/Owner proposing the construction and upgrading of the public water system. Design of water facilities shall be by a registered engineer in the State of Washington and will be reviewed by the City Engineer for compliance with these standards.
- G. Prior to the installation of any water meters, all Public Works improvements must be completed and approved including granting of right-of-way or easements, and all applicable fees must be paid.
- H. Issuance of building permits for new construction of single family residences within new subdivisions shall not occur until final Public Works approval of all improvements is given. For commercial projects, building permits may be issued upon completion and acceptance of the required fire protection facilities, providing the necessary easements and paying all required fees and connection charges. Certificates of occupancy will not be granted until final Public Works approval and acceptance of all improvements is given.

#### 4.02 DESIGN STANDARDS

- A. The design of any water extension/connection shall conform to these standards and any applicable standards as set forth in other chapters of these standards.
- B. The layout of extensions shall provide for the future continuation and/or "looping" of the existing system as determined by the City Engineer and Water Superintendent. In addition, main extensions shall be extended as required in Chapter 1.
- C. The following GENERAL CONDITIONS and those in Chapter 1, section 1A.085 shall be included on any plans dealing with the water system when a permit is required.
  - 1. The City shall be given 72 hours notice prior to scheduling a shutdown of the water system. The existing valve must be pressure tested to City standards prior to connection. If an existing valve fails to pass the test, the Contractor shall make the necessary provisions to test the new line prior to connection to the existing system or install a new valve.
  - 2. The existing valves shall be operated **only** by City employees.

## CHAPTER 4 – WATER

3. During the construction of mains and services, the Contractor shall cap, plug, or secure the ends of such lines whenever the project is shut down at the end of the day so that contaminants will not enter the lines.
4. All lines shall be chlorinated and tested by the Contractor, with a representative of the City present, in conformance with the standard specifications. Dechlorination will be done by City forces at Contractor expense.

### 4.03 WATERMANS

- A. Water mains shall be sized to provide adequate domestic and fire flows at the required residual pressure. Fire flow minimum requirements are ultimately determined by the Port Angeles Fire Department and may be modified based upon an approved fire sprinkler plan for the development. The generally accepted flow and pressure minimum guidelines are as follows:
  1. DOMESTIC DEMAND - PEAK INSTANT FLOW
    - a. Single Family Residential - 2.0 GPM at 30 psi service minimum
    - b. Multi-Family Residential - 1.0 GPM at 30 psi service minimum
    - c. Commercial - 1.0 GPM at 30 psi service minimum
    - d. Industrial - 1.0 GPM at 30 psi service minimum. Generally low impact unless water used in the industrial process and/or peak use occurs during system peaks.
    - e. Irrigation: By system capacity - significant users schedule for off-peak usage of water.
  2. FIRE FLOW
    - a. Minimum Single Family Residential - 1,000 GPM at 20 psi unless the area or subdivision is provided with an automatic sprinkler system.
    - b. Multi-Family Residential/Commercial/Industrial - 1,500 GPM at 20 psi as per the Uniform Fire Code as adopted by the City of Port Angeles, or as modified by the "Guide for Determination of required Fire Flow" Insurance Services Office (ISO), December 1974, and/or approved by the Port Angeles Fire Department. Requirements may be modified based upon a Fire Department approved fire sprinkler plan for the development.
  3. SYSTEM PRESSURES
    - a. Recommended Domestic - Minimum 30 psi at maximum instantaneous demand and 20 psi during fire demand. (Maximum 120 psi.)
    - b. The City requires a customer to provide and install a pressure reducing valve (PRV) on private lines where necessary in accordance with the Uniform Plumbing Code. PRV's required for pressures above 80 psi.
    - c. Normal operating pressures of not less than 40 psi nor more than 100 psi shall be maintained at service connections to the distribution system, except that during periods of peak domestic and fire demand, the pressure shall be not be less than 20 psi.
- B. The City Engineer shall be consulted as to the size of the watermain. In general, the minimum size main which will be allowed to serve the development is 8-inch inside diameter, unless otherwise approved. Larger size mains are required in specific areas outlined in the Water System Plan. Nothing shall preclude the City Engineer from requiring the installation of a larger sized main in areas not addressed in the Plan, if the City Engineer determines that a larger size is needed to meet fire protection requirements or for future service. The Developer may be eligible for a Developer Reimbursement Agreement to recover additional costs.
- C. Dead-end mains shall not be permitted unless specifically approved, and the distribution system to a development shall be interconnected so that pressures throughout the system will tend to become equalized under varying rates and locations of maximum demand. If a dead-end main is approved by the City, the main shall be extended to the farthest boundary of the development and a City standard 2" minimum blow-off

## CHAPTER 4 – WATER

shall be provided. It is not the intent to set arbitrary standards with regard to pipe sizes and layout; therefore, in special situations where it can be shown that domestic supply requirements and fire protection requirements can be met at existing and anticipated future pressures, the City will consider each design on its individual merits.

- D. For commercial, multi-family, and industrial applications the minimum main size shall be an 8 inch loop or larger dead end line based on fire flow demands.
- E. All pipe for water mains shall have flexible gasketed joints and shall comply with one of the following types:
  - 1. **DUCTILE IRON PIPE:** Ductile iron pipe shall conform to AWWA C151 Class 52 and have a cement mortar lining conforming to AWWA C104 and APWA 9-30.1(1), Class 52 minimum. All pipes shall be joined using non-restrained joints which shall be rubber gaskets, push on type or mechanical joint conforming to AWWA C111.
  - 2. **PVC PIPE:** Four (4) inch and larger PVC pipe shall meet AWWA C900, pressure class 200 psi and APWA 9-30.1(5)A. PVC pipe smaller than four (4) inch shall conform to APWA 9-30.1(5)B, pressure class 200 psi. PVC pipe will not be allowed in areas where the Water Superintendent has reason to believe that petroleum or other hazardous products may reside in existing soils or will have the possibility to do so. The Superintendent may require that soil samples be taken in accordance with ANSI/AWWA C105/A21.5 in order to determine soil content.
- F. All fittings for ductile iron pipe or PVC pipe shall be ductile iron compact fittings conforming to AWWA C153 or Class 250 gray iron conforming to AWWA C110 and C111 and APWA 9-30.2(1). All shall be cement mortar lined conforming to AWWA C104. Plain end fittings shall be ductile iron if mechanical joint retainer glands are installed on the plain ends. All fittings shall be connected by flanges or mechanical joints.
- G. All pipe and services shall be installed with continuous tracer tape.
- H. The minimum cover for all water mains from top of pipe to finished grade shall be 36 inches, unless otherwise approved.

### 4.04 EASEMENTS

Easements for watermains and other facilities shall be provided in accordance with Chapter 1.

### 4.05 CONNECTION TO THE CITY WATER SYSTEM

- A. Not less than 48 hours prior to the time that the extension is partially or fully completed and connection to the City Water System is needed, the developer shall contact the City to schedule the connection to the City system. The actual connection to the City system will be made by City personnel at the expense of the developer, unless specific permission is granted to the Contractor by the City Engineer to perform the connection. The connection will not be made until the developer's Contractor demonstrates through acceptable test results that the extension has been properly hydrostatically tested and disinfected.
- B. It shall be the Contractor's responsibility to field verify the location and depth of the existing main and the fittings required to make the connections to the existing mains. The Contractor shall completely excavate the area where the connection is to be made by the City crews.

### 4.06 SERVICE INTERRUPTION

The Contractor shall give the City a minimum of 72 hours notice prior to scheduling a planned cut-in, live tap or other connection to the existing system. The Contractor shall notify all customers involved or affected by any water service interruption 24 hours prior to interrupting service. The Contractor shall make every effort to schedule water main construction with a minimum interruption of water service. In certain situations, the City may need to restrict the scheduling of water main shutdowns, so as not to impose unnecessary shutdowns during specific periods to existing customers.

### 4.07 HYDRANTS AND FIRE CONNECTIONS

- A. Fire hydrants shall be placed at street intersections wherever possible, and located to minimize the hazard of damage by traffic. Unless otherwise required, the following shall apply for hydrant number and location.

## CHAPTER 4 – WATER

1. Fire hydrants shall be located as per the Uniform Fire Code, most recent edition adopted by the City of Port Angeles.
  2. Single-Family homes provided with residential sprinklers may be 500 feet away from a hydrant.
- B. The lead from the service main to the fire hydrant shall be ductile iron cement mortar lined Class 52 no less than 6 inches in diameter.
- C. Fire hydrants shall comply with AWWA Standard C502 Standard for Dry-Barrel fire hydrants with 5-1/4 inch main valve opening, two 2-1/2 inch hose nozzles (National Standard thread), one 4-inch pumper nozzle (Pacific Coast Thread) with a "Storz" fitting compatible with a 5" Storz hose coupling that meets the NFPA Fire Hose Connection Standard in Chapter 6 of the latest edition of NFPA 1963. The hydrant shall have a 6-inch mechanical joint shoe connection with a minimum 42" bury depth. Hydrants shall be Mueller Centurion A-423, Clow F-2500, M&H 929, or approved equal.
- D. In zones of the distribution system where the static pressure exceeds 100 psi, only hydrants of the Cory or AVR 2700/AVR 2780 design will be acceptable
- E. Hydrants shall be bagged until the system is accepted and approved.
- F. Fire hydrants shall be set in accordance with the City Standard Drawing.
- G. All hydrants to be painted chrome yellow. Low flow hydrants to be identified by painting bonnet red.
- H. Requirements for the use, size and location of a Fire Department Connection (FDC) and/or post indicator valve shall be per the Uniform Fire Code, most recent edition adopted by the City of Port Angeles. The location of FDC shall be shown on the plans and approved by the Fire Department.
- I. Fire hydrants must be installed, tested, and accepted per APWA 7-14 prior to the issuance of a building permit. The flow testing of the hydrant shall be witnessed by the Fire Department.
- J. Fire systems shall be separate or separated from domestic systems in such a way that both systems can be operated and tested at their respective pressures.

### 4.08 VALVES

- A. All valves and fittings shall be ductile iron with ANSI flanges or mechanical joint ends. All existing valves are to be operated **ONLY** by City employees, unless specific permission to operate valves is granted to the Contractor by the City Engineer. Valves shall open counterclockwise and shall be equipped with a 2-inch square AWWA standard operating nut. Valves shall be installed in accordance with APWA 7-12.
- B. The distribution system shall be equipped with a sufficient number of valves to facilitate repair and maintenance and so that no single shutdown will result in shutting down a transmission main, or necessitate the removal from service of a length of pipe greater than 500 feet in school, commercial, industrial, or multiple-family dwelling areas, or greater than 800 feet in other zoning areas. In no case shall more than two fire hydrants be removed from service. The valves shall be so located that any section of main can be shut down without going to more than three locations to close valves.
- C. Valves shall be located on tees or crosses at street intersections, or at other locations determined by the City. Generally, there shall be two valves on each tee and three valves on each cross. If it is necessary to install valves between street intersections, they shall be located on property lines between lots. Air and vacuum relief valve installations shall be made at the principal high points of the system. Specific requirements for valve spacing will be made at the plan review stage.
- D. Gate Valves shall conform with the requirements of AWWA C509-87 for gate valves for ordinary water works service, except as superseded by the following: They shall be iron body with epoxy coating inside and out, resilient seat rubber attached to gate. The valves shall be non-rising stem, open by turning counterclockwise, and shall be equipped with standard 2-inch square operating nuts. Valves shall be equipped with double "O-ring" packing. Valves to be Mueller, M&H Kennedy, Clow R/W or Waterous Series 500.
- E. Butterfly Valves shall conform to AWWA C504, Class 150B, Pratt Groundhog, Dresser 450, Mueller Lineseal III, or approved equal. Butterfly valves shall be used on all lines 14 inches and larger.

## CHAPTER 4 – WATER

- F. Valve Boxes shall be cast iron valve boxes, Olympic Foundry VB2B, VB2C; RICH 940A, 940B; or equal. Valve box "ears" shall be installed in line with the main or hydrant lead.
- G. Fire Sprinkler System Check Valves shall be installed on all fire sprinkler systems on upstream side of alarm check or control valve. It shall be a U.L. approved soft seat check valve, Rockwell or approved equal. In addition, a backflow prevention device shall be installed when required by the City Engineer or Water Superintendent.
- H. Valves outside of paved areas shall be marked with a flexible delineator marker post with a blue reflector, such as Carsonite markers.

### 4.09 CASING PIPE

Steel casing pipe shall be schedule 20 steel or equal. Pipe spacers shall be Cascade style CC5 with 8 inch runners as available from Cascade Waterworks. Casing pipe and spacers shall be sized for the pipe being installed. Install minimum of three spacers per section of pipe.

### 4.10 AIR / VACUUM RELIEF VALVE

- A. Air/vacuum relief valves (ARV) shall be 1 or 2 inch APCO combination air relief valve as shown on the City Standard Drawings.
- B. The installation shall be set at the high point of the line when required. Where possible, pipes are to be graded to prevent the need for an air relief valve. Air relief valves may not be required when services are in the immediate vicinity.

### 4.11 BLOWOFF ASSEMBLY

A City standard 2" minimum blowoff assembly shall be installed on all permanent dead-end runs approved by the City, if fire hydrants are not located at the end. Wherever possible, the blowoff shall be installed in the street right-of-way, three feet from the curb and gutter. In no case shall the location be such that there is a possibility of back-siphonage into the distribution system. On water mains which will be extended in the future, the valve which operates the blowoff assembly shall be the same size as the main and provided with a concrete thrust block. The installation shall be as shown on the City Standard Drawing.

### 4.12 BACKFLOW PREVENTION

All water system connections to serve buildings or properties with domestic potable water, fire sprinkler systems, or irrigation systems shall comply with the minimum backflow requirements established by the Department of Health and the City Backflow Ordinance in PAMC 13.28 & 13.32 and Public Works and Utilities Department Policy No. PW-903.

### 4.13 SERVICE CONNECTION

- A. All service connections relating to new development shall be installed by the developer at the time of mainline construction. After the lines have been constructed, tested, disinfected, and accepted by the City, the owner or builder may apply for a water meter to be set by the City. The meter will be installed after all applicable fees have been paid.
- B. When water is desired to a parcel fronting an existing main but not served by an existing water service, an application must be made to the City and upon approval of the application and payment of the fees the City will tap the main and install the meter box, setter, and meter.
- C. Service lines shall be one (1) inch high density polyethylene pipe, copper tube size, minimum pressure class 200 psi Phillips Drisco 5100 Ultra-Line. No glued joints will be accepted on 1" service lines. 1½" and 2" PVC services may be glued. Service lines shall be installed 45 degrees off the main. Tracer tape shall be installed on all service lines per general conditions.
- D. Copper tubing type K shall be used in areas where the Water Superintendent has reason to believe that petroleum or other hazardous products may reside in the existing soils or will have the possibility to do so. The Superintendent may require that soil samples be taken in accordance with ANSI/AWWA C105/A21.5 in order to determine the soil content.

## CHAPTER 4 – WATER

- E. Service saddles shall be painted ductile iron or nylon coated ductile iron with stainless steel straps and shall be Romac style 101S on 1" tap, 202S on 1½ or larger taps. Romac 202N, Rockwell 313 or approved equal are required for hot or corrosive soils. All clamps shall have rubber gasket and iron pipe threaded outlets.
- F. Corporation stop shall be all bronze and shall be Ford Type F-500 or approved equal with iron pipe threads conforming to AWWA C800. Stainless steel inserts shall be used with pack joints and polyethylene pipe.
- G. Master meters will not be allowed for services to more than one building. An approved backflow prevention system must be installed in conjunction with any master meter.

### 4.14 WATER METERS/SETTERS/BOX

All water meters shall be purchased and installed by the City and paid by the owner/developer. Meter box and setters shall be furnished and installed by Owner/Developer. 1" meter setters shall be Ford VH74-12 [male swivel end] with Carson 1419B-15 meter box with inspection lid. Larger meter setters/box shall be as specified by the City Engineer.

### 4.15 WATER MAIN/SANITARY SEWER CROSSINGS

- A. The Contractor shall maintain a minimum of 18 inches of vertical separation between crossings of sanitary sewers and water mains. The minimum cover for water main may be reduced to 18 inches upon approval of the City Engineer to provide for as much vertical separation as possible.
- B. The longest standard length of water pipe shall be installed so that the joints will fall equidistant from any sewer crossing. In some cases where minimum separation cannot be maintained, it may be necessary to encase the water pipe and/or sewer service in a pipe or concrete. No concrete shall be installed unless specifically directed and inspected by the City.

### 4.16 TRENCH EXCAVATION, BEDDING AND BACKFILL

All work in this section shall be accomplished in accordance with Section 7-08 of the most recent Standard Specifications for Road, Bridge and Municipal Construction, published by the Washington State Department of Transportation, and as contained herein.

- A. Clearing and grubbing where required shall be performed within the easement or public right-of-way as permitted by the City and/or governing agency. Debris resulting from the clearing and grubbing shall be disposed of by the owner or Contractor in accordance with the terms of all applicable permits.
- B. The trench shall be kept free from water until jointing is complete. Surface water shall be diverted so as not to enter the trench. The owner shall maintain sufficient pumping equipment on the job to insure that these provisions are carried out.
- C. Trenching and shoring operations shall not proceed more than 100 feet in advance of pipe laying without approval of the City.
- D. Backfilling with native materials excavated from the trenches may only occur with the written approval of the City Engineer.
- E. In paved areas within the public right of way the Contractor shall use controlled density backfill per City Standard Drawing. Alternative materials may only be accepted with the written approval by the City Engineer.

### 4.17 THRUST BLOCKING

The location of thrust blocking shall be shown on the plans. Thrust block concrete shall be poured against undisturbed earth. A plastic barrier shall be placed between all thrust blocks and any fittings. See City Standard Drawings.

### 4.18 STREET PATCHING AND RESTORATION

See Chapter 3 sections 3B.170 and 3B.180 for requirements regarding patching and trench restoration.

## CHAPTER 4 – WATER

### 4.19 HYDROSTATIC TESTS

- A. Prior to the acceptance of the work, the installation shall be subjected to a hydrostatic pressure test in accordance with WSDOT Standard Specifications - 7-09.3(23). A main shall not be tested until the lines have been flushed of chlorine. The main shall be tested between valves. All testing shall be witnessed by the City Inspector.
- B. The Contractor shall provide all necessary equipment and shall perform all work connected with the tests. Tests shall be made after all connections have been made and the roadway section has been constructed to grade. The Contractor shall keep a record of the flushing and volume of water used from the City system in flushing and testing and shall provide the City Inspector with the report prior to acceptance of the main.
- C. For private water lines, the Fire Department requires that these lines be tested to 200 psi for 2 hours.

### 4.20 DISINFECTION AND FLUSHING

- A. Disinfection of water mains shall be accomplished by the Contractor, in accordance with the requirements of WSDOT 7-09.3(24) and of the Washington Department of Health and in a manner satisfactory to the City.
- B. At no time shall chlorinated water from a new main be flushed into a body of fresh water. This is to include lakes, rivers, streams, drainage ways, and any and all other waters where fish or other water life can be expected.
- C. Bacteriological samples for testing can only be taken on Monday through Thursday until 3:00 P.M. when the testing lab is open. These tests will be accomplished by the City at the Contractor's expense.

- End of Chapter 4

# CHAPTER 4 – WATER

## APPENDICES

### A. CITY STANDARD DRAWINGS

1. Thrust Blocking Details (2 sheets)
2. Fire Hydrant Assembly Type A and B
3. Water Service Connection
4. 2" Blow-off Assembly
5. 1" Air/Vacuum Relief Valve
6. 2" Air/Vacuum Relief Valve
7. Valve Box, Support Block and Thrust Block
8. Standard Locations for Underground Utilities
9. Master Water Meter Assembly

### Filename

thrustblock.dwg  
hydrants.dwg  
waterservice.dwg  
blowoff.dwg  
1inairrelief.dwg  
2inairrelief.dwg  
gatevalve.dwg  
utilitylocations.dwg  
mastermeter.dwg

### B. WSDOT STANDARD PLANS

1. Blocking for Convex Vertical Bends

Section B



# STANDARD DETAIL

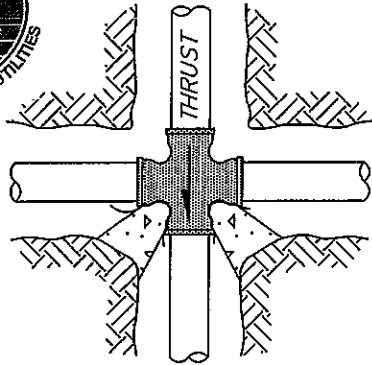

UNBALANCED CROSS

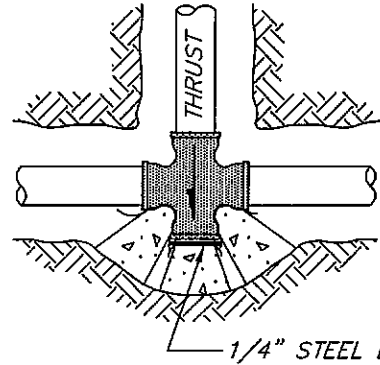

CROSS WITH SHACKLED PLUG

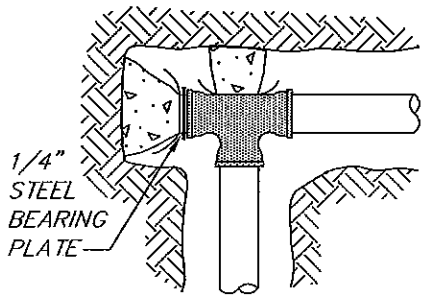

PLUGGED TEE

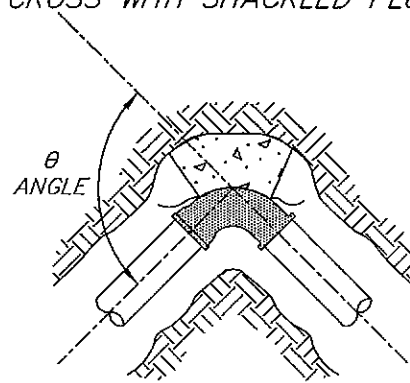

HORIZONTAL BENDS

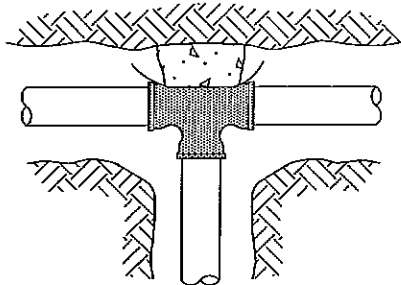

TEE

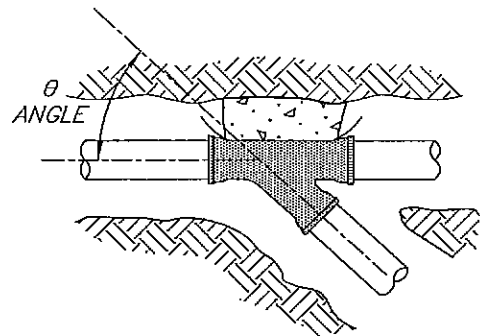

WYE BRANCH

**NOTES:**

1. ALL BLOCKING TO BE CONCRETE CLASS 3000
2. LOCATE THRUST BLOCKING AT ALL LOCATIONS NOTED ABOVE AND AS REQUIRED BY THE CITY ENGINEER.
3. ALL BLOCKING TO BEAR AGAINST UNDISTURBED NATIVE SOIL
4. PLACE 15# FELT ROOFING MATERIAL OR 6MIL PVC SHEETING BETWEEN FITTING AND CONCRETE.
5. SEE SHEET 2 FOR BEARING AREA.

ALL WORK AND MATERIAL TO BE IN ACCORDANCE WITH THE CURRENT WASHINGTON STATE DEPARTMENT OF TRANSPORTATION "STANDARD SPECIFICATIONS FOR ROAD, BRIDGE, AND MUNICIPAL CONSTRUCTION"

APPROVED BY  
CITY ENGINEER *[Signature]*  
FILE NAME: THRUSTBLOCK.DWG

DATE : 9/08/95  
REVISED : 3/15/06

THRUST BLOCKING DETAILS  
SHEET 1 OF 2



# STANDARD DETAIL

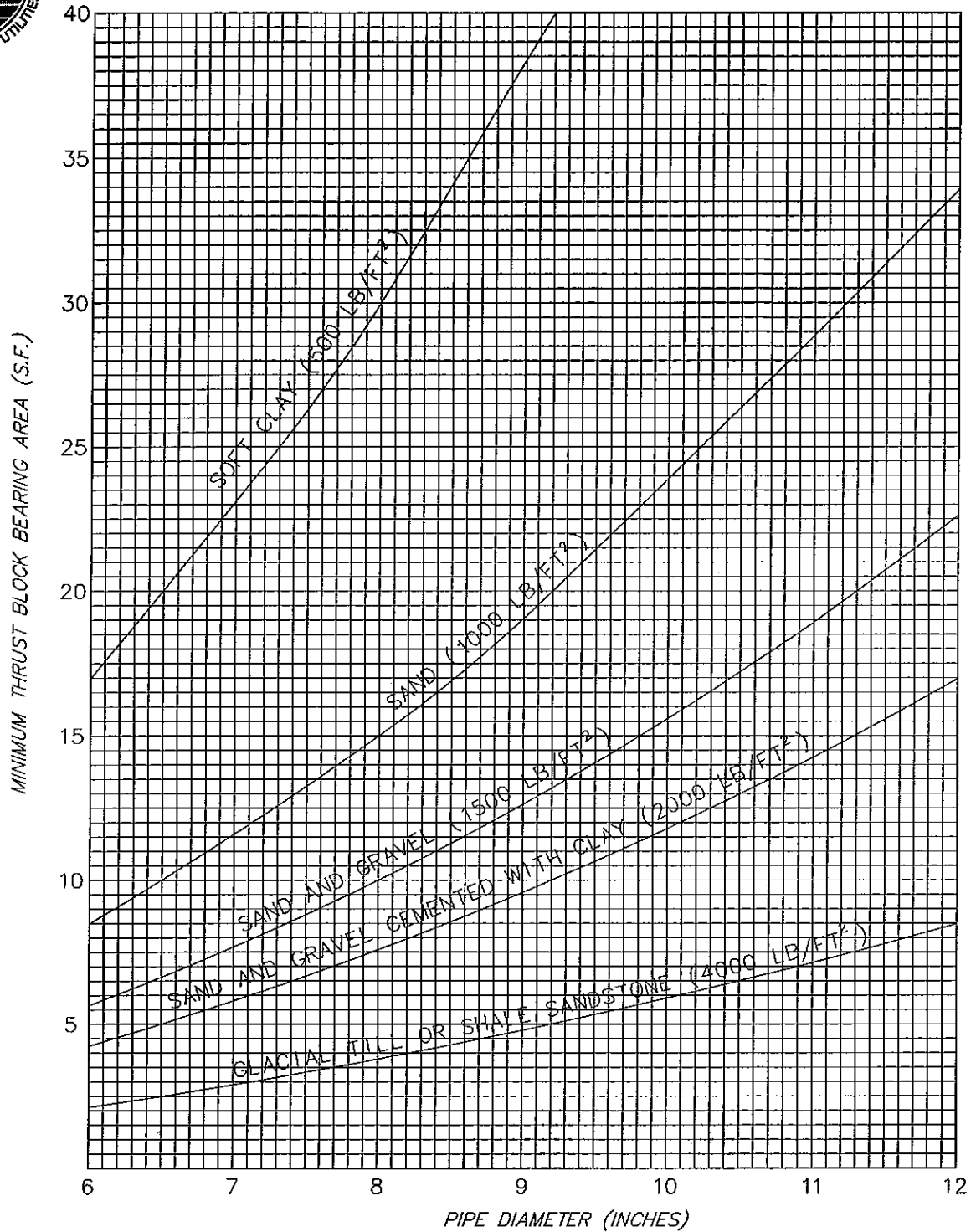

## NOTES:

1. BASED ON 300 PSI TEST PRESSURE AND BEARING VALUES OF DRY SOILS.
2. VALUES FROM CURVES ARE FOR TEES, CROSS AND DEADENDS, I.E.; STRAIGHT LINE THRUST.  
 FOR 90° BEND: USE 1.4X VALUE FROM CURVE.  
 FOR 45° BEND: USE 0.8X VALUE FROM CURVE.  
 FOR 22 1/2° BEND: USE 0.4X VALUE FROM CURVE.  
 FOR OTHER ANGLES ( $\theta$ ): USE  $(2\sin \theta/2) \times$  VALUE FROM CURVE.
3. FOR CONDITIONS NOT COVERED BY CURVES, SPECIAL THRUST BLOCKS MUST BE COMPUTED AND APPROVED.

APPROVED BY  
CITY ENGINEER

DATE : 9/08/95

REVISED : 3/15/06

THRUST BLOCK DETAILS  
SHEET 2 OF 2

FILE NAME: THRUSTBLOCK.DWG



# STANDARD DETAIL

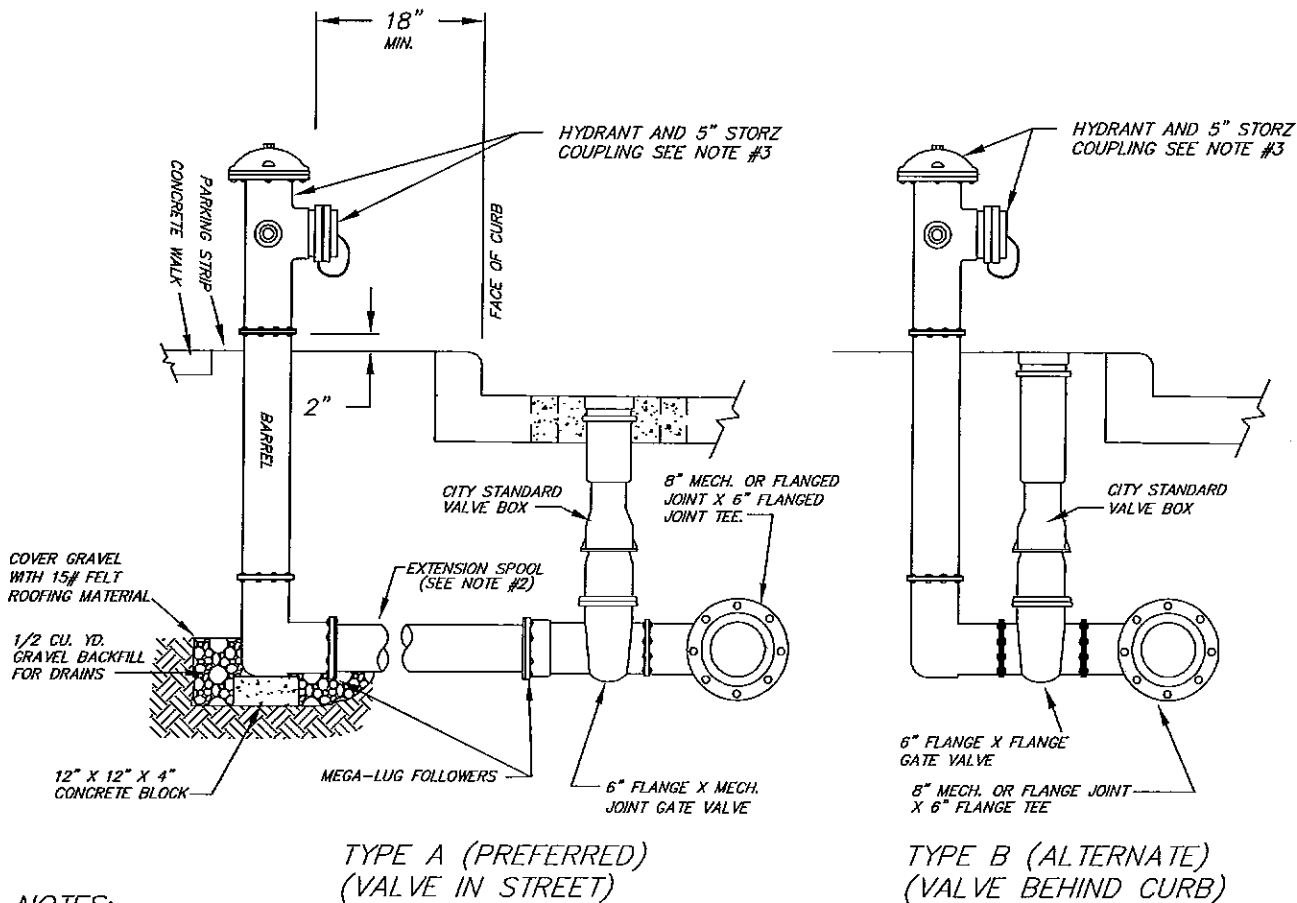

**NOTES:**

1. FIRE HYDRANTS SHALL BE PLACED AT STREET INTERSECTIONS WHEREVER POSSIBLE, AND LOCATED TO MINIMIZE THE HAZARD OF DAMAGE BY TRAFFIC. UNLESS OTHERWISE REQUIRED, THE FOLLOWING SHALL APPLY FOR HYDRANT NUMBER AND LOCATION:
  - a. FIRE HYDRANTS SHALL BE LOCATED AS PER THE UNIFORM FIRE CODE, MOST RECENT EDITION ADOPTED BY THE CITY OF PORT ANGELES.
  - b. SINGLE FAMILY HOMES PROVIDED WITH RESIDENTIAL SPRINKLERS MAY BE 500 FEET AWAY FROM A HYDRANT.
2. THE LEAD FROM THE SERVICE MAIN TO THE FIRE HYDRANT SHALL BE DUCTILE IRON CEMENT MORTAR LINED CLASS 52 NO LESS THAN 6 INCHES IN DIAMETER.
3. FIRE HYDRANTS SHALL COMPLY WITH AWWA STANDARD C502 STANDARD FOR DRY-BARREL FIRE HYDRANTS WITH 5-1/4 INCH MAIN VALVE OPENING, TWO 2-1/2 INCH HOSE NOZZLES (NATIONAL STANDARD THREAD), ONE 4-INCH PUMPER NOZZLE (PACIFIC COAST THREAD). THE 4" PUMPER NOZZLE SHALL BE FITTED WITH AN AFTERMARKET "STORZ" FITTING COMPATIBLE WITH 5" STORZ HOSE COUPLING THAT MEETS THE NFPA FIRE HOSE CONNECTION STANDARD IN CHAPTER 6 OF THE LATEST EDITION OF NFPA 1963. THE FIRE HYDRANT SHALL HAVE A 6" MECHANICAL JOINT SHOE CONNECTION, HYDRANT MINIMUM BURIAL DEPTH OF 42".
4. HYDRANTS SHALL BE BAGGED UNTIL THE SYSTEM IS ACCEPTED AND APPROVED.
5. ALL HYDRANTS TO BE PAINTED CHROME YELLOW. LOW FLOW HYDRANTS TO BE IDENTIFIED BY PAINTING BONNET RED.
6. FIRE HYDRANTS MUST BE INSTALLED, TESTED AND ACCEPTED PER APWA 7-14 PRIOR TO THE ISSUANCE OF A BUILDING PERMIT. THE FLOW TESTING OF THE HYDRANT SHALL BE WITNESSED BY THE FIRE DEPARTMENT.
7. FIRE SYSTEMS SHALL BE SEPARATE OR SEPARATED FROM DOMESTIC SYSTEMS IN SUCH A WAY THAT BOTH SYSTEMS CAN BE OPERATED AND TESTED AT THEIR RESPECTIVE PRESSURES.

ALL WORK AND MATERIAL TO BE IN ACCORDANCE WITH THE CURRENT WASHINGTON STATE DEPARTMENT OF TRANSPORTATION "STANDARD SPECIFICATIONS FOR ROAD, BRIDGE, AND MUNICIPAL CONSTRUCTION"

APPROVED BY CITY ENGINEER: <i>[Signature]</i>	DATE: 9/08/95 REVISED: 3/15/06	FIRE HYDRANT ASSEMBLY TYPE A & B
FILE NAME: HYDRANTS.DWG		



# STANDARD DETAIL

## SECTION A-A

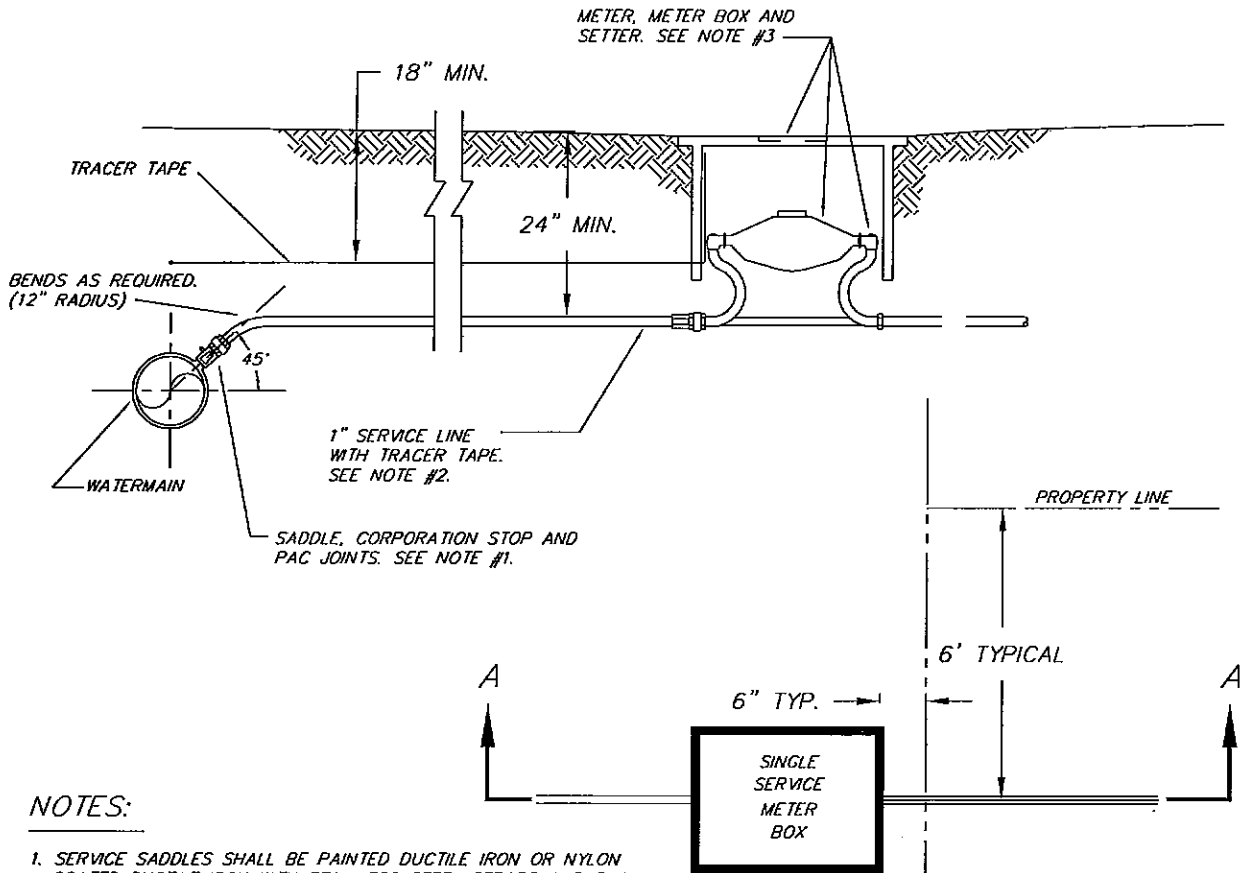

### NOTES:

1. SERVICE SADDLES SHALL BE PAINTED DUCTILE IRON OR NYLON COATED DUCTILE IRON WITH STAINLESS STEEL STRAPS AND SHALL BE ROMAC STYLE 101S ON 1" TAP, 202S ON 1-1/2" OR LARGER TAPS. ROMAC 202N, ROCKWELL 313 OR APPROVED EQUALS ARE REQUIRED FOR HOT OR CORROSIVE SOILS. ALL CLAMPS SHALL HAVE RUBBER GASKET AND IRON PIPE THREADED OUTLETS. CORPORATION STOP SHALL BE ALL BRONZE AND SHALL BE FORD TYPE F-500 OR APPROVED EQUAL WITH IRON PIPE THREADS CONFORMING TO AWWA C800. STAINLESS STEEL INSERTS SHALL BE USED WITH PACK JOINTS AND POLYETHELENE PIPE.
2. SERVICE LINES SHALL BE ONE (1) INCH HIGH DENSITY POLY-ETHELENE PIPE, COPPER TUBE SIZE, MINIMUM PRESSURE CLASS 200 PDI PHILLIPS DRISCO, 5100 ULTRA-LINE. NO GLUED JOINTS WILL BE ACCEPTED ON 1" SERVICE LINES. 1-1/2" AND 2" PVC SERVICES MAY BE GLUED. SERVICE LINES SHALL BE INSTALLED 45 DEGREES OFF THE MAIN. TRACER TAPE SHALL BE INSTALLED ON ALL SERVICE LINES PER GENERAL CONDITIONS. COPPER TUBING TYPE K SHALL BE USED IN AREAS REQUIRED BY THE WATER SUPERINTENDENT.
3. ALL WATER METERS SHALL BE PURCHASED AND INSTALLED BY THE CITY AND PAID BY THE OWNER/DEVELOPER. METER BOX AND SETTERS SHALL BE FURNISHED AND INSTALLED BY OWNER/DEVELOPER. 1" METER SETTERS SHALL BE FORD VH 74-12 (MALE SWIVEL END) WITH CARSON 1419B-15 METER BOX WITH INSPECTION LID. LARGER METER SETTERS/BOX SHALL BE AS SPECIFIED BY CITY.
4. DUAL WATER SERVICE FROM A SINGLE TAP SHALL NOT BE APPROVED.

ALL WORK AND MATERIAL TO BE IN ACCORDANCE WITH THE CURRENT WASHINGTON STATE DEPARTMENT OF TRANSPORTATION "STANDARD SPECIFICATIONS FOR ROAD, BRIDGE, AND MUNICIPAL CONSTRUCTION"

APPROVED BY CITY ENGINEER	DATE: 9/29/95 REVISED: 3/15/06	<h2 style="margin: 0;">WATER SERVICE</h2>
FILE NAME: WATERSERVICE.DWG		



# STANDARD DETAIL

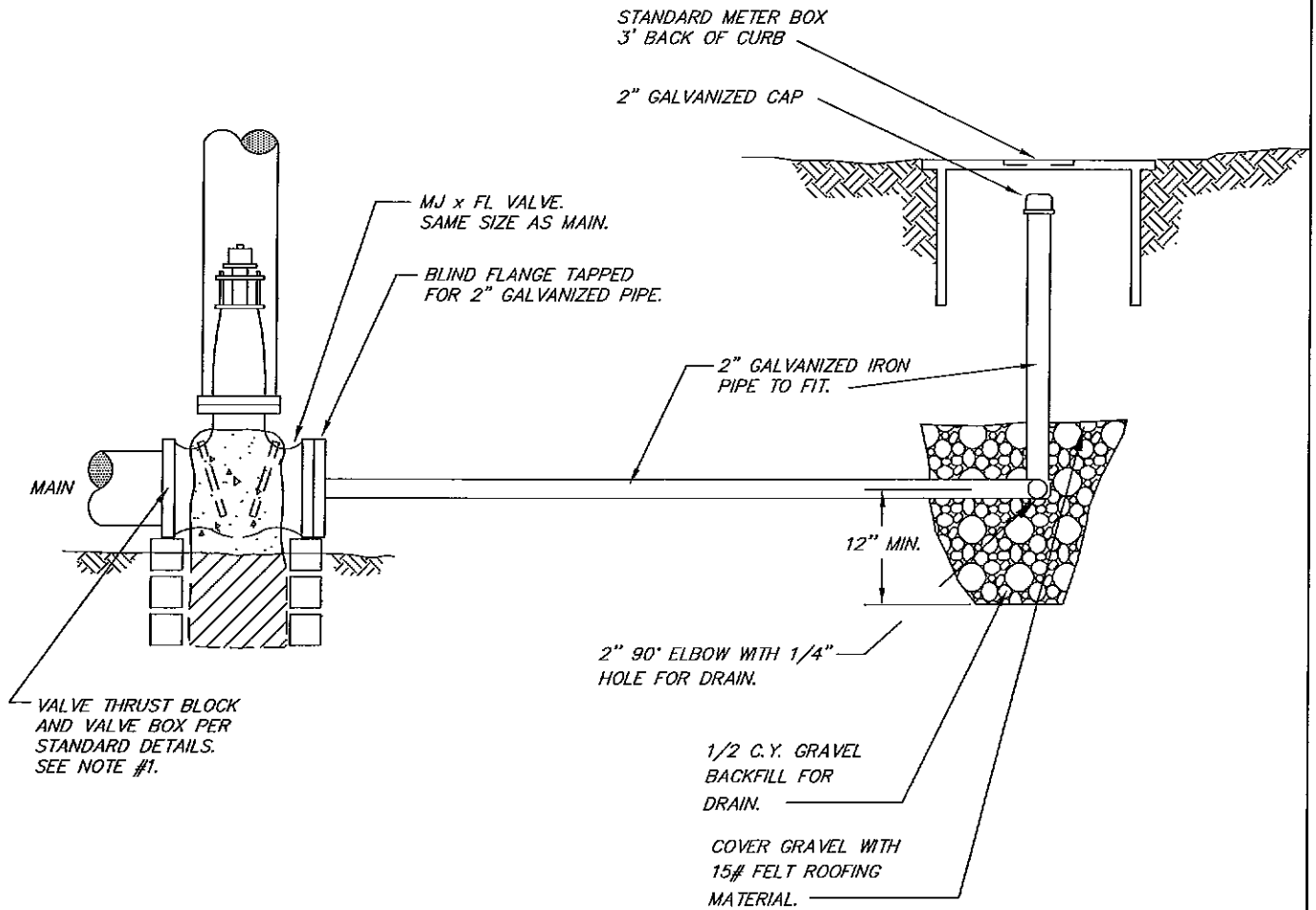

**NOTE:**

1. BLIND FLANGE FOR FUTURE MAIN EXTENSION SHALL BE CLEAN OF THRUST BLOCK CONCRETE.

ALL WORK AND MATERIAL TO BE IN ACCORDANCE WITH THE CURRENT WASHINGTON STATE DEPARTMENT OF TRANSPORTATION "STANDARD SPECIFICATIONS FOR ROAD, BRIDGE, AND MUNICIPAL CONSTRUCTION"

APPROVED BY CITY ENGINEER :	DATE : 10/02/95 REVISED : 3/15/06	<h2>2" BLOWOFF ASSEMBLY</h2>
FILE NAME: BLOWOFF.DWG		



# STANDARD DETAIL

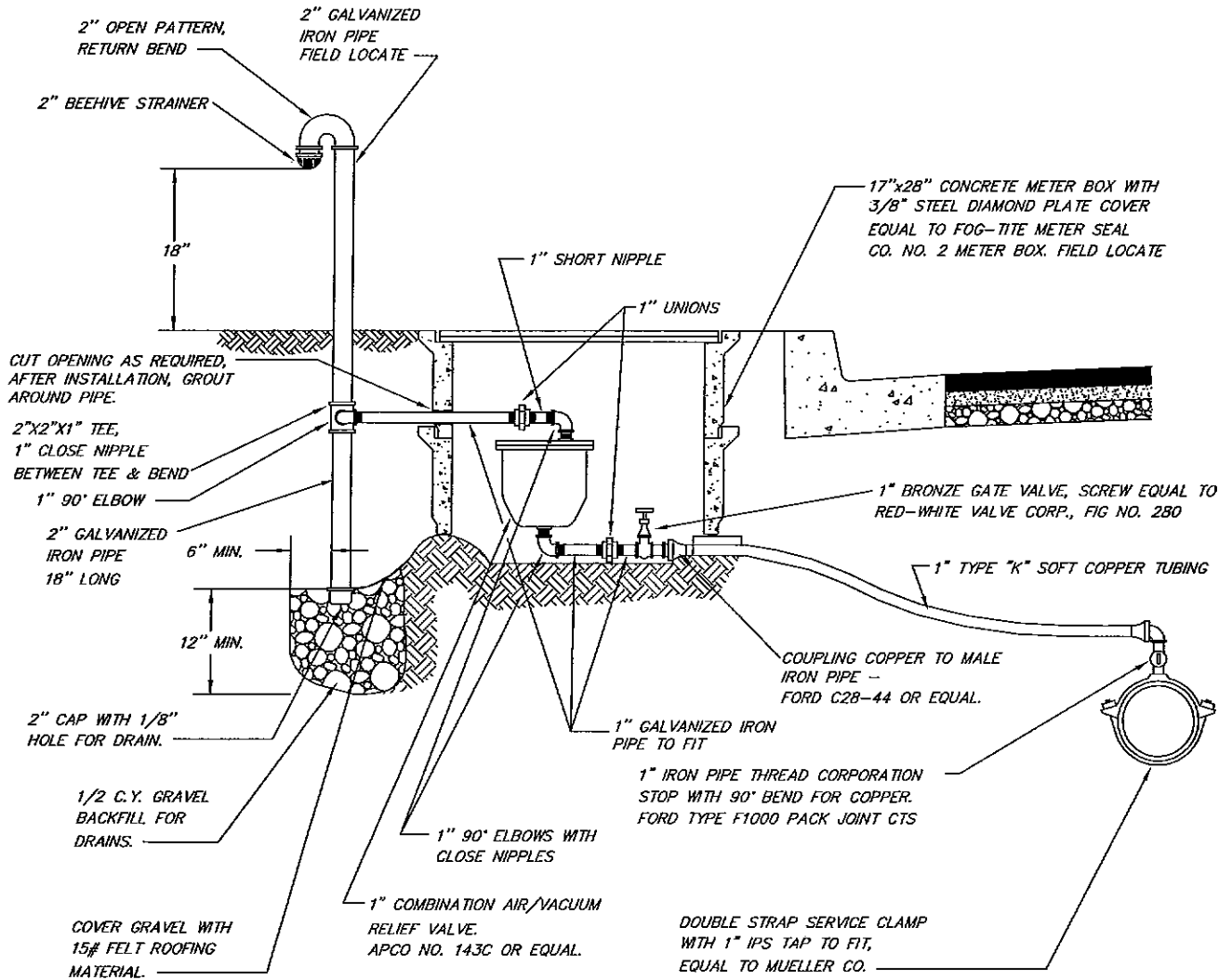

**NOTE:**

1. REQUIRED FOR 12" AND SMALLER MAINS.
2. AIR/VACUUM RELIEF VALVE ASSEMBLY SHALL BE INSTALLED AT HIGHEST POINT OF LINE. IF HIGH POINT FALLS IN A LOCATION WHERE ASSEMBLY CANNOT BE INSTALLED, PROVIDE ADDITIONAL DEPTH OF LINE TO CREATE A HIGH POINT AT A LOCATION WHERE ASSEMBLY CAN BE INSTALLED.

ALL WORK AND MATERIAL TO BE IN ACCORDANCE WITH THE CURRENT WASHINGTON STATE DEPARTMENT OF TRANSPORTATION "STANDARD SPECIFICATIONS FOR ROAD, BRIDGE, AND MUNICIPAL CONSTRUCTION"

APPROVED BY CITY ENGINEER	DATE : 9/08/95 REVISED : 3/15/06	<h2>1" AIR/VACUUM RELIEF VALVE</h2>
FILE NAME: 11AIRRELIEF.DWG		



# STANDARD DETAIL

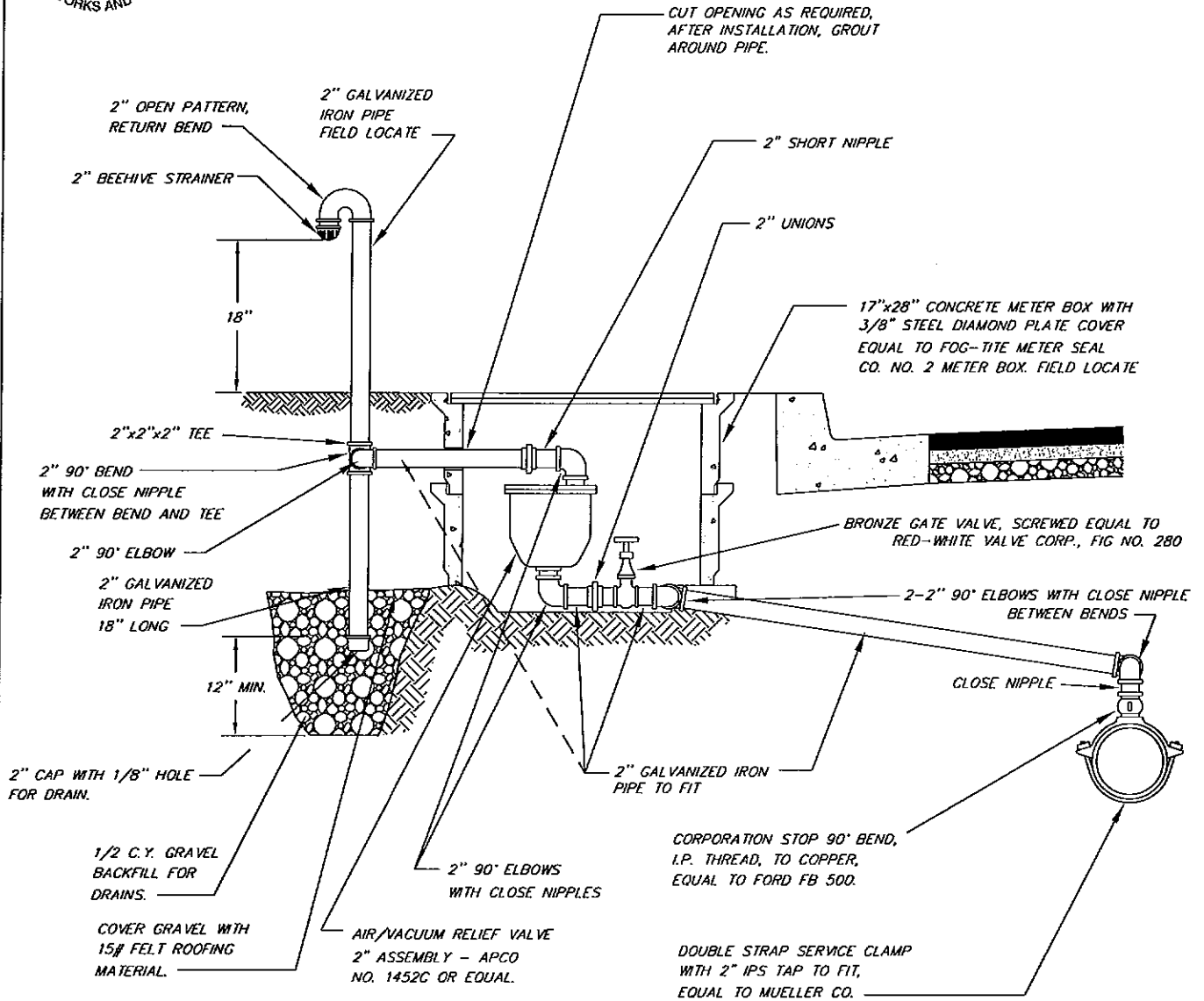

## NOTE:

1. REQUIRED FOR MAINS LARGER THAN 12 INCHES.
2. AIR/VACUUM RELIEF VALVE ASSEMBLY SHALL BE INSTALLED AT HIGHEST POINT OF LINE. IF HIGH POINT FALLS IN A LOCATION WHERE ASSEMBLY CANNOT BE INSTALLED, PROVIDE ADDITIONAL DEPTH OF LINE TO CREATE A HIGH POINT AT A LOCATION WHERE ASSEMBLY CAN BE INSTALLED.

ALL WORK AND MATERIAL TO BE IN ACCORDANCE WITH THE CURRENT WASHINGTON STATE DEPARTMENT OF TRANSPORTATION "STANDARD SPECIFICATIONS FOR ROAD, BRIDGE, AND MUNICIPAL CONSTRUCTION"

APPROVED BY CITY ENGINEER <i>[Signature]</i>	DATE : 9/08/95 REVISED : 3/15/06	<h2>2" AIR/VACUUM RELIEF VALVE</h2>
FILE NAME: 2INAIRRELIEF.DWG		



# STANDARD DETAIL

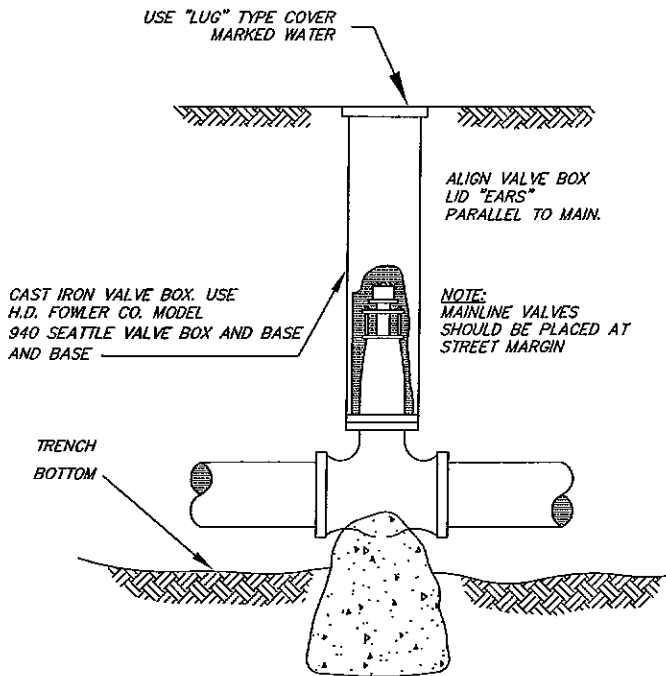

VALVE BOX AND SUPPORT BLOCK

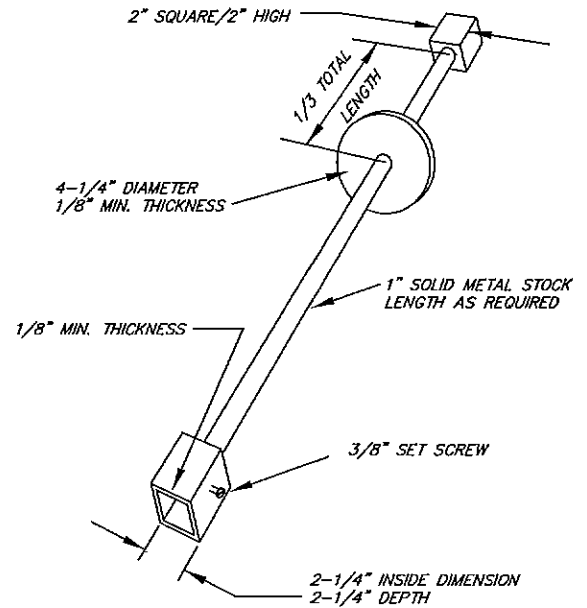

VALVE STEM EXTENSION  
(REQUIRED WHEN DEPTH EXCEEDS 5')

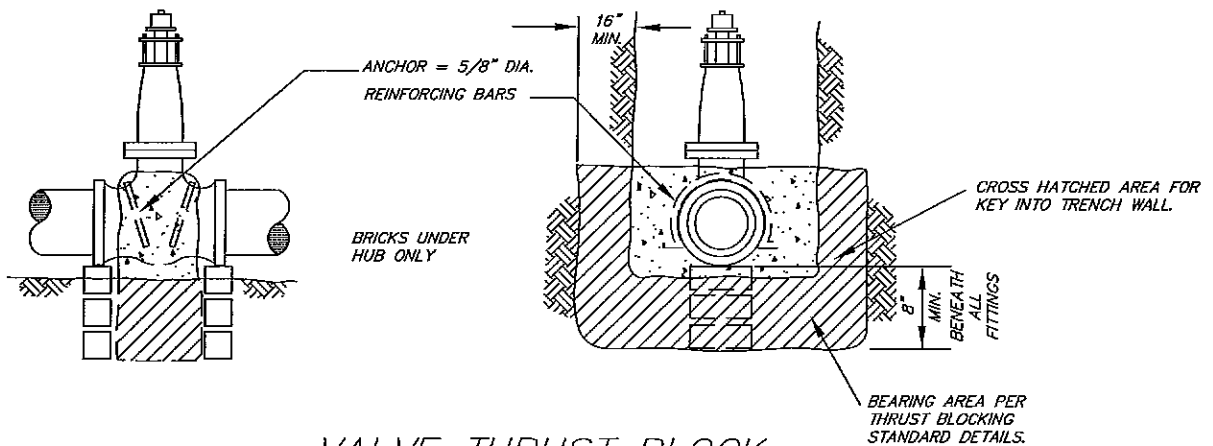

VALVE THRUST BLOCK

**NOTE:**

1. CONCRETE SHALL BE CLASS 3000
2. VALVE THRUST BLOCKS TO BE INSTALLED AT EACH VALVE LOCATION.

ALL WORK AND MATERIAL TO BE IN ACCORDANCE WITH THE CURRENT WASHINGTON STATE DEPARTMENT OF TRANSPORTATION "STANDARD SPECIFICATIONS FOR ROAD, BRIDGE, AND MUNICIPAL CONSTRUCTION"

APPROVED BY  
CITY ENGINEER *[Signature]*  
FILE NAME: GATEVALVE.DWG

DATE : 10/02/95  
REVISED : 3/15/06

VALVE BOX, SUPPORT BLOCK AND THRUST BLOCK



# STANDARD DETAIL

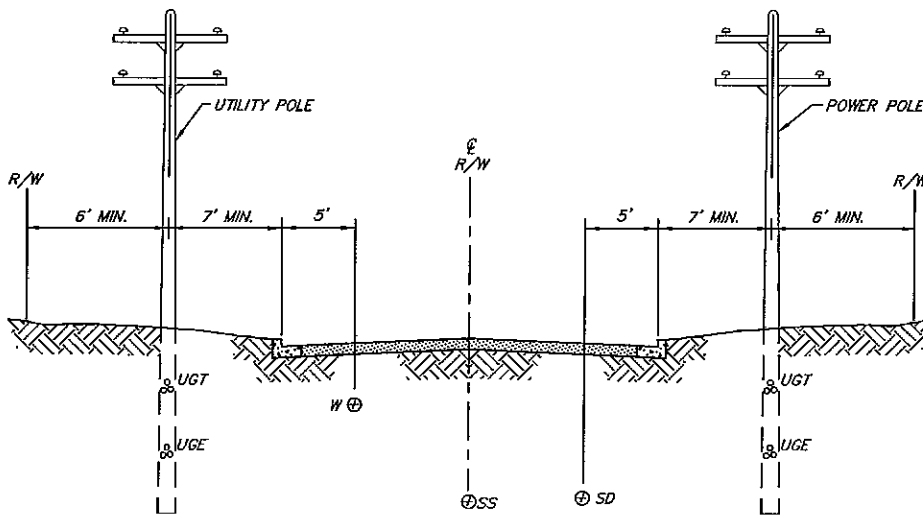

STREET

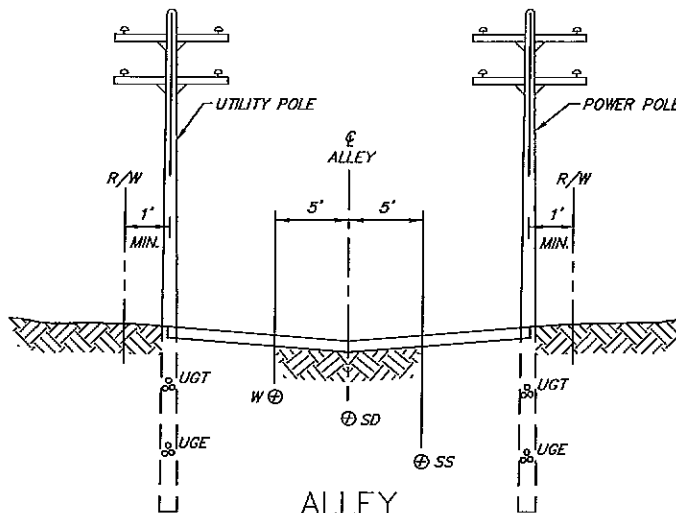

ALLEY

NOTE:

UTILITY/POWER POLE LOCATIONS AT INTERSECTIONS SHALL BE COORDINATED WITH ENGINEERING DIVISION.

SYMBOL	UNDERGROUND SERVICE	MIN. DEPTH
UGE	UNDERGROUND ELECTRICAL PRIMARY/SECONDARY	4'-0"
UGT	UNDERGROUND TV/PHONE	3'-0"
SS	SANITARY SEWER	8'-0"
SD	STORM DRAIN	5'-0"
W	WATER	3'-0"



CALL 48 HOURS  
BEFORE YOU DIG  
1-800-424-5555

APPROVED BY  
CITY ENGINEER: *[Signature]*  
FILE NAME: UTILITYLOCATION.DWG

DATE: 10/03/95  
REVISED: 3/15/06

STANDARD LOCATIONS FOR  
UNDERGROUND UTILITIES



# STANDARD DETAIL

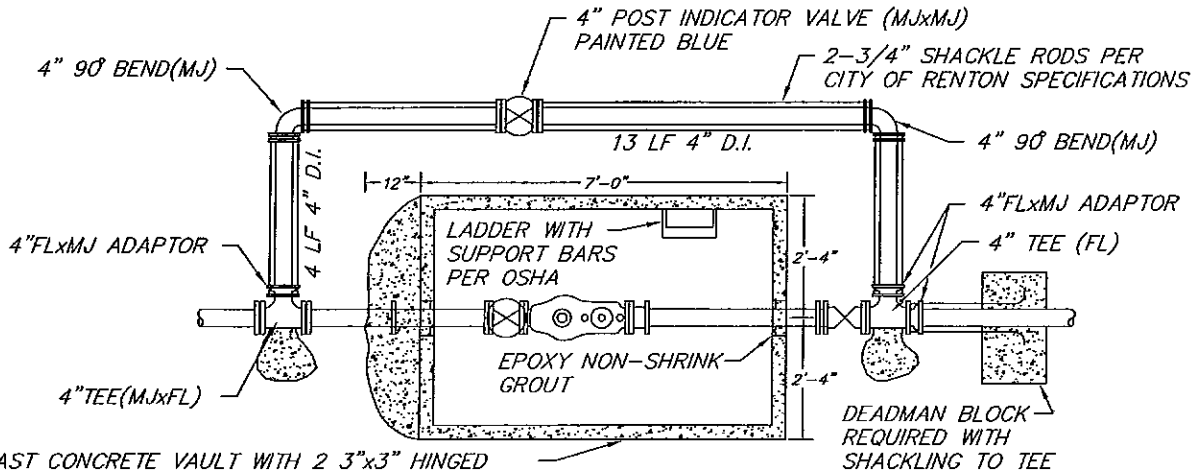

PRECAST CONCRETE VAULT WITH 2 3"x3" HINGED STEEL PLATE COVER. OUTSIDE DIMENSIONS 4'-8"x7'-0". (EUAL TO PIPE INC., OR UTILITY VAULT WITH 57-7L-B, 2 3'x3' DIAMOND PLATE DOORS)

6", 4" OR 3" GATE VALVE (FLxFL)  
NON-RISING STEM WITH HAND WHEEL  
EUAL TO MUELLER CO. A-2380-6.

TWO PIECE CAST IRON VALVE BOX,  
EUAL TO OLYMPIC FOUNDRY CO.  
STANDARD 8" TOP SECTION, WITH  
REGULAR BASE SECTION LENGTH  
TO FIT.

6" OR 4" (FLxPE) CEMENT  
LINED DUCTILE IRON PIPE  
CLASS 52 3'-6" LONG  
WITH COLLAR 20" FROM  
P.E. EUAL TO THOSE  
SUPPLIED BY PACIFIC  
WATER WORKS CO. INC.

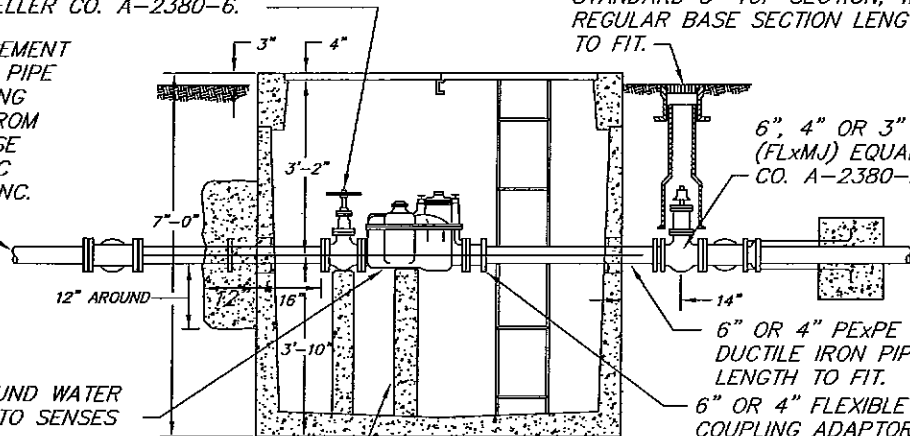

6", 4" OR 3" COMPOUND WATER  
METER (FL) EUAL TO SENSES  
COMPOUND METER.  
REDUCE AT METER WITH  
4"x3" FLxFL CONCENTRIC  
REDUCER.

CONCRETE SUPPORT  
PADS OR ADJUSTABLE  
PIPE SUPPORTS.

6" OR 4" PEXPE CEMENT LINED  
DUCTILE IRON PIPE CLASS 52.  
LENGTH TO FIT.  
6" OR 4" FLEXIBLE FLANGED  
COUPLING ADAPTOR, ROMAC OR  
APPROVED EUAL.

## GENERAL NOTES:

ALL METERS AND BACKFLOW PREVENTION DEVICE COMBINATIONS ARE NOT SHOWN OR INCLUDED IN THE STANDARD DETAIL DRAWINGS. IF YOUR PARTICULAR COMBINATION IS NOT SHOWN, AN APPROVED DRAWING WILL BE REQUIRED BY THE ENGINEERING DIVISION PRIOR TO INSTALLATION. THE PRINCIPAL REQUIREMENTS REGARDING VAULT SIZING ARE THE LENGTH OF FITTINGS OR THEIR CLEARANCE FROM THE VAULT WALLS, (WHICH CLEARANCE SHALL BE A MINIMUM OF 12" FROM THE ENDS AND THE SIDE CLEARANCE SHOULD BE AS TYPICALLY SHOWN ON THE VARIOUS STANDARD DETAILS.)

NOTE: DEADMAN BLOCK SHALL BE DESIGNED AND INSTALLED SO IT BEARS AGAINST SUFFICIENT UNDISTURBED EARTH SO AS TO SUPPORT THE DESIGNED THRUST.

APPROVED BY  
CITY ENGINEER

DATE : 4/19/95

REVISED : 3/15/06

FILE NAME: MASTERMETER.DWG

MASTER  
WATER METER



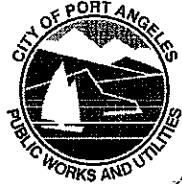

# STANDARD DETAIL

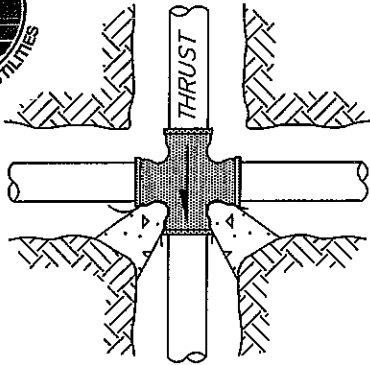

UNBALANCED CROSS

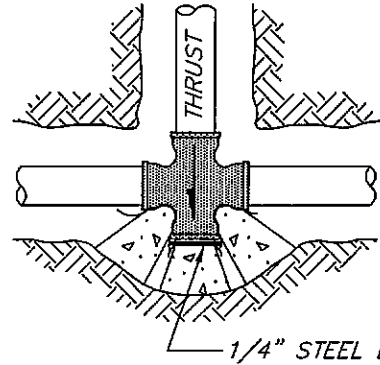

CROSS WITH SHACKLED PLUG

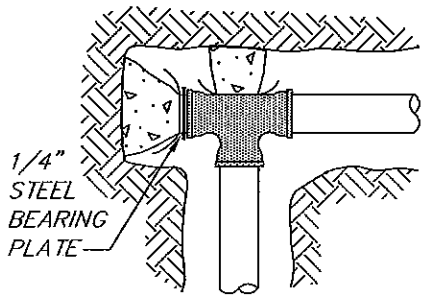

PLUGGED TEE

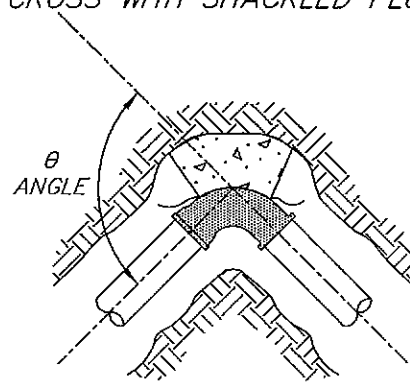

HORIZONTAL BENDS

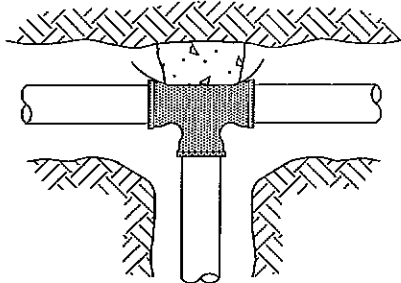

TEE

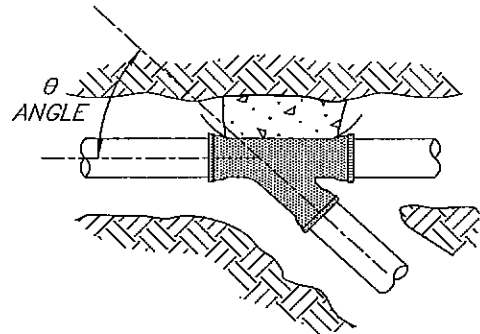

WYE BRANCH

**NOTES:**

1. ALL BLOCKING TO BE CONCRETE CLASS 3000
2. LOCATE THRUST BLOCKING AT ALL LOCATIONS NOTED ABOVE AND AS REQUIRED BY THE CITY ENGINEER.
3. ALL BLOCKING TO BEAR AGAINST UNDISTURBED NATIVE SOIL
4. PLACE 15# FELT ROOFING MATERIAL OR 6MIL PVC SHEETING BETWEEN FITTING AND CONCRETE.
5. SEE SHEET 2 FOR BEARING AREA.

ALL WORK AND MATERIAL TO BE IN ACCORDANCE WITH THE CURRENT WASHINGTON STATE DEPARTMENT OF TRANSPORTATION "STANDARD SPECIFICATIONS FOR ROAD, BRIDGE, AND MUNICIPAL CONSTRUCTION"

APPROVED BY CITY ENGINEER	DATE : 9/08/95 REVISED : 3/15/06	THRUST BLOCKING DETAILS SHEET 1 OF 2
FILE NAME: THRUSTBLOCK.DWG		



# STANDARD DETAIL

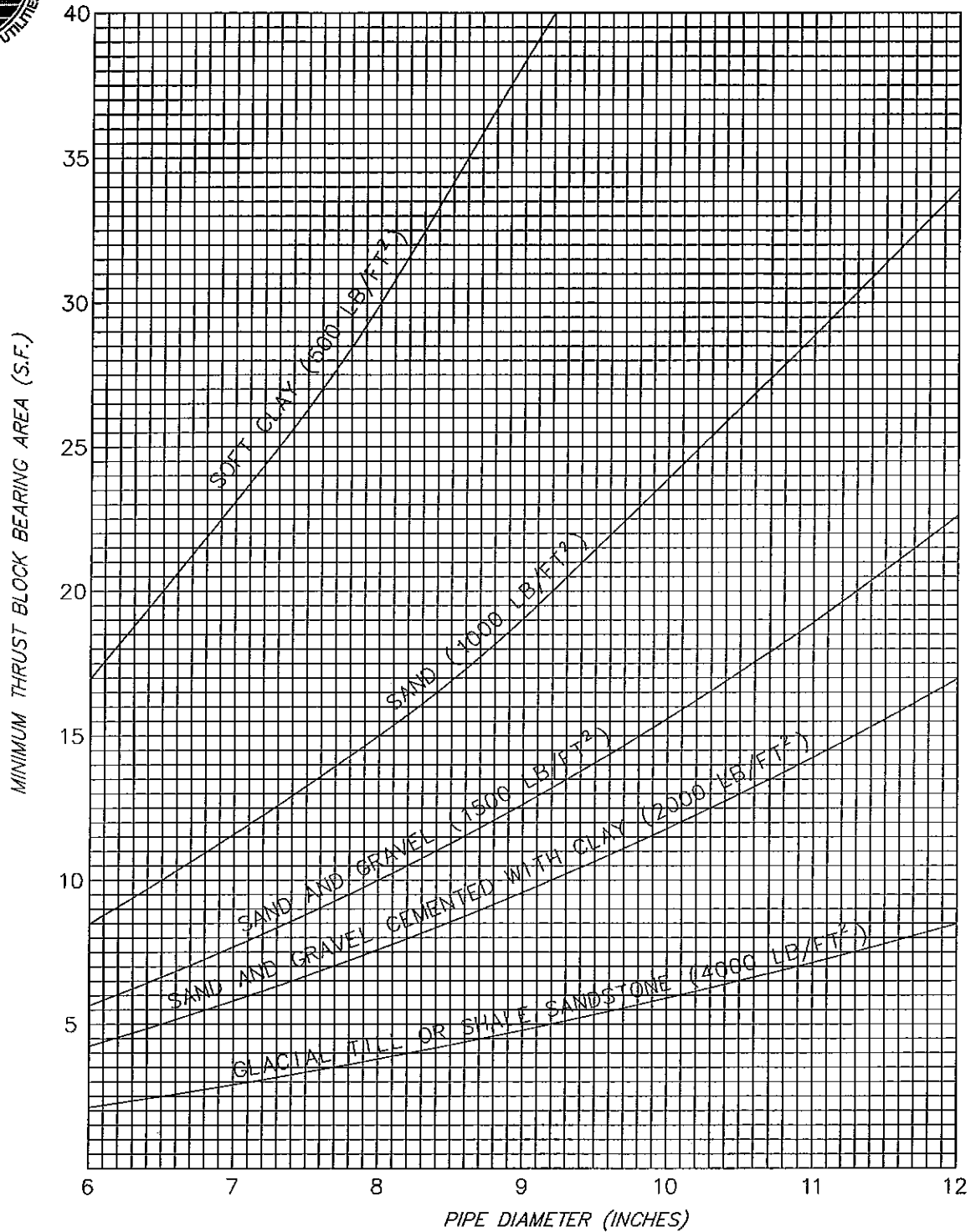

## NOTES:

1. BASED ON 300 PSI TEST PRESSURE AND BEARING VALUES OF DRY SOILS.
2. VALUES FROM CURVES ARE FOR TEES, CROSS AND DEADENDS, I.E.; STRAIGHT LINE THRUST.  
 FOR 90° BEND: USE 1.4X VALUE FROM CURVE.  
 FOR 45° BEND: USE 0.8X VALUE FROM CURVE.  
 FOR 22 1/2° BEND: USE 0.4X VALUE FROM CURVE.  
 FOR OTHER ANGLES ( $\theta$ ): USE  $(2\sin \theta/2) \times$  VALUE FROM CURVE.
3. FOR CONDITIONS NOT COVERED BY CURVES, SPECIAL THRUST BLOCKS MUST BE COMPUTED AND APPROVED.

APPROVED BY  
CITY ENGINEER

DATE : 9/08/95

REVISED : 3/15/06

THRUST BLOCK DETAILS  
SHEET 2 OF 2

FILE NAME: THRUSTBLOCK.DWG



# STANDARD DETAIL

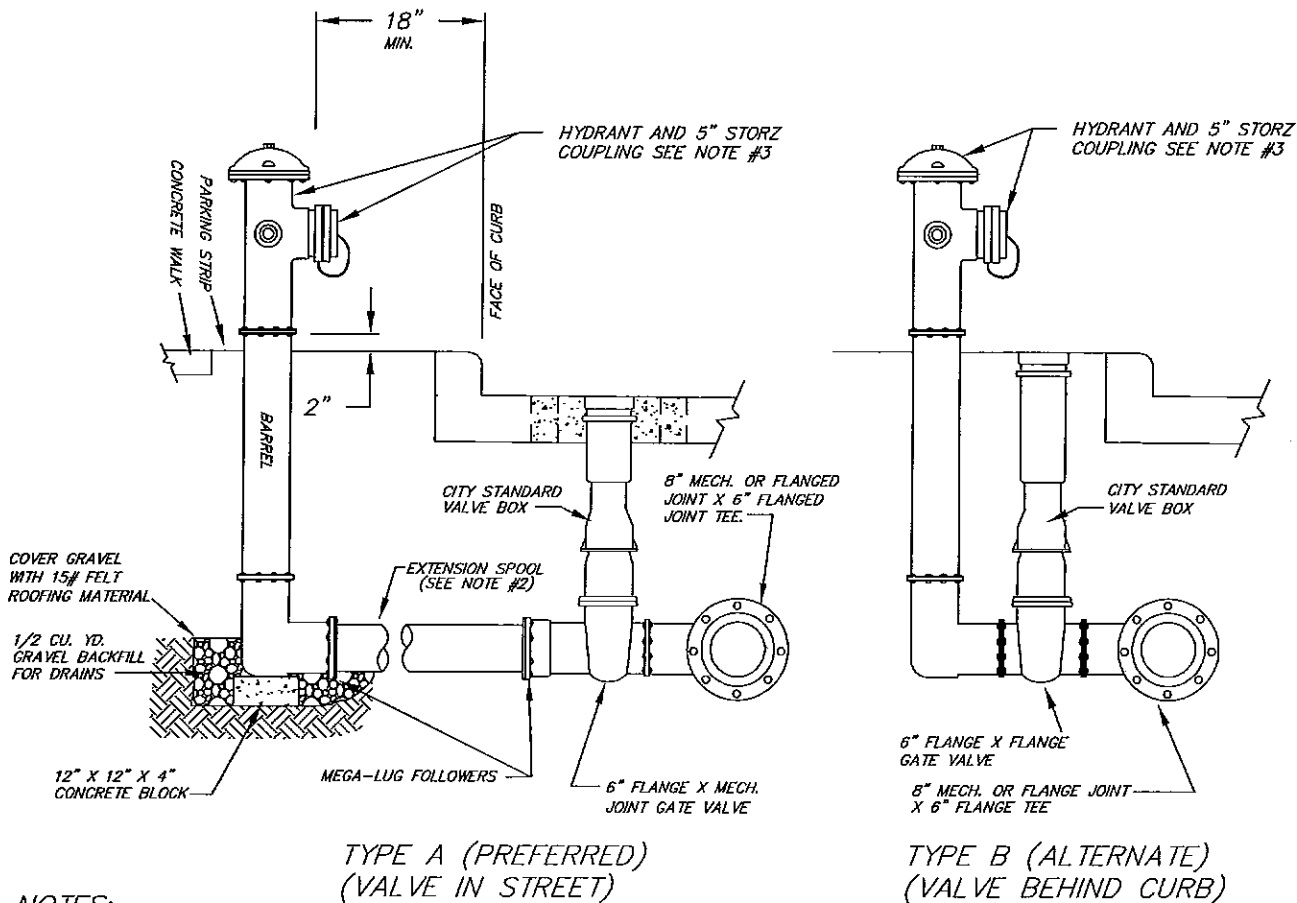

**NOTES:**

1. FIRE HYDRANTS SHALL BE PLACED AT STREET INTERSECTIONS WHEREVER POSSIBLE, AND LOCATED TO MINIMIZE THE HAZARD OF DAMAGE BY TRAFFIC. UNLESS OTHERWISE REQUIRED, THE FOLLOWING SHALL APPLY FOR HYDRANT NUMBER AND LOCATION:
  - a. FIRE HYDRANTS SHALL BE LOCATED AS PER THE UNIFORM FIRE CODE, MOST RECENT EDITION ADOPTED BY THE CITY OF PORT ANGELES.
  - b. SINGLE FAMILY HOMES PROVIDED WITH RESIDENTIAL SPRINKLERS MAY BE 500 FEET AWAY FROM A HYDRANT.
2. THE LEAD FROM THE SERVICE MAIN TO THE FIRE HYDRANT SHALL BE DUCTILE IRON CEMENT MORTAR LINED CLASS 52 NO LESS THAN 6 INCHES IN DIAMETER.
3. FIRE HYDRANTS SHALL COMPLY WITH AWWA STANDARD C502 STANDARD FOR DRY-BARREL FIRE HYDRANTS WITH 5-1/4 INCH MAIN VALVE OPENING, TWO 2-1/2 INCH HOSE NOZZLES (NATIONAL STANDARD THREAD), ONE 4-INCH PUMPER NOZZLE (PACIFIC COAST THREAD). THE 4" PUMPER NOZZLE SHALL BE FITTED WITH AN AFTERMARKET "STORZ" FITTING COMPATIBLE WITH 5" STORZ HOSE COUPLING THAT MEETS THE NFPA FIRE HOSE CONNECTION STANDARD IN CHAPTER 6 OF THE LATEST EDITION OF NFPA 1963. THE FIRE HYDRANT SHALL HAVE A 6" MECHANICAL JOINT SHOE CONNECTION, HYDRANT MINIMUM BURIAL DEPTH OF 42".
4. HYDRANTS SHALL BE BAGGED UNTIL THE SYSTEM IS ACCEPTED AND APPROVED.
5. ALL HYDRANTS TO BE PAINTED CHROME YELLOW. LOW FLOW HYDRANTS TO BE IDENTIFIED BY PAINTING BONNET RED.
6. FIRE HYDRANTS MUST BE INSTALLED, TESTED AND ACCEPTED PER APWA 7-14 PRIOR TO THE ISSUANCE OF A BUILDING PERMIT. THE FLOW TESTING OF THE HYDRANT SHALL BE WITNESSED BY THE FIRE DEPARTMENT.
7. FIRE SYSTEMS SHALL BE SEPARATE OR SEPARATED FROM DOMESTIC SYSTEMS IN SUCH A WAY THAT BOTH SYSTEMS CAN BE OPERATED AND TESTED AT THEIR RESPECTIVE PRESSURES.

ALL WORK AND MATERIAL TO BE IN ACCORDANCE WITH THE CURRENT WASHINGTON STATE DEPARTMENT OF TRANSPORTATION "STANDARD SPECIFICATIONS FOR ROAD, BRIDGE, AND MUNICIPAL CONSTRUCTION"

APPROVED BY CITY ENGINEER: <i>[Signature]</i>	DATE: 9/08/95 REVISED: 3/15/06	FIRE HYDRANT ASSEMBLY TYPE A & B
FILE NAME: HYDRANTS.DWG		



# STANDARD DETAIL

## SECTION A-A

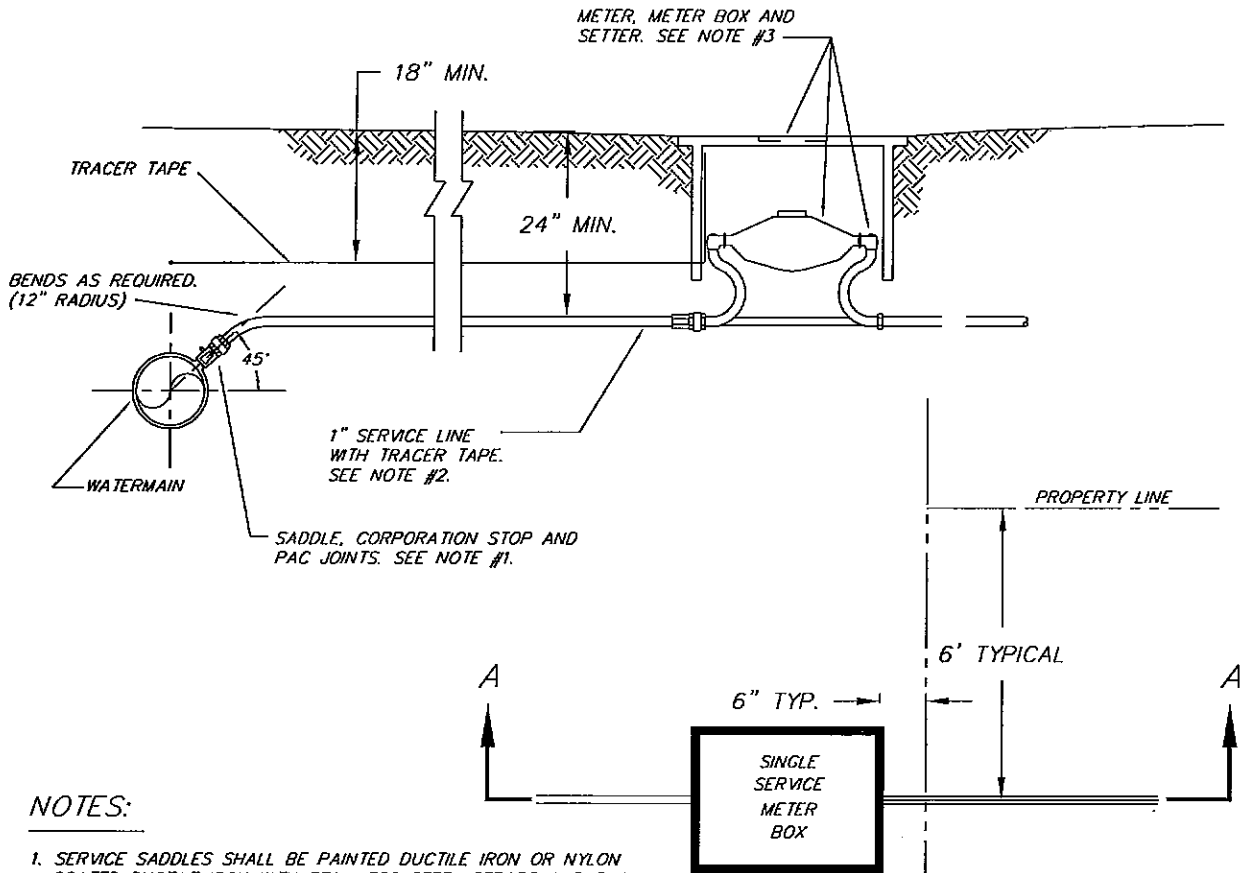

### NOTES:

1. SERVICE SADDLES SHALL BE PAINTED DUCTILE IRON OR NYLON COATED DUCTILE IRON WITH STAINLESS STEEL STRAPS AND SHALL BE ROMAC STYLE 101S ON 1" TAP, 202S ON 1-1/2" OR LARGER TAPS. ROMAC 202N, ROCKWELL 313 OR APPROVED EQUALS ARE REQUIRED FOR HOT OR CORROSIVE SOILS. ALL CLAMPS SHALL HAVE RUBBER GASKET AND IRON PIPE THREADED OUTLETS. CORPORATION STOP SHALL BE ALL BRONZE AND SHALL BE FORD TYPE F-500 OR APPROVED EQUAL WITH IRON PIPE THREADS CONFORMING TO AWWA C800. STAINLESS STEEL INSERTS SHALL BE USED WITH PACK JOINTS AND POLYETHELENE PIPE.
2. SERVICE LINES SHALL BE ONE (1) INCH HIGH DENSITY POLY-ETHELENE PIPE, COPPER TUBE SIZE, MINIMUM PRESSURE CLASS 200 PDI PHILLIPS DRISCO, 5100 ULTRA-LINE. NO GLUED JOINTS WILL BE ACCEPTED ON 1" SERVICE LINES. 1-1/2" AND 2" PVC SERVICES MAY BE GLUED. SERVICE LINES SHALL BE INSTALLED 45 DEGREES OFF THE MAIN. TRACER TAPE SHALL BE INSTALLED ON ALL SERVICE LINES PER GENERAL CONDITIONS. COPPER TUBING TYPE K SHALL BE USED IN AREAS REQUIRED BY THE WATER SUPERINTENDENT.
3. ALL WATER METERS SHALL BE PURCHASED AND INSTALLED BY THE CITY AND PAID BY THE OWNER/DEVELOPER. METER BOX AND SETTERS SHALL BE FURNISHED AND INSTALLED BY OWNER/DEVELOPER. 1" METER SETTERS SHALL BE FORD VH 74-12 (MALE SWIVEL END) WITH CARSON 1419B-15 METER BOX WITH INSPECTION LID. LARGER METER SETTERS/BOX SHALL BE AS SPECIFIED BY CITY.
4. DUAL WATER SERVICE FROM A SINGLE TAP SHALL NOT BE APPROVED.

ALL WORK AND MATERIAL TO BE IN ACCORDANCE WITH THE CURRENT WASHINGTON STATE DEPARTMENT OF TRANSPORTATION "STANDARD SPECIFICATIONS FOR ROAD, BRIDGE, AND MUNICIPAL CONSTRUCTION"

APPROVED BY CITY ENGINEER	DATE: 9/29/95 REVISED: 3/15/06	<h2 style="margin: 0;">WATER SERVICE</h2>
FILE NAME: WATERSERVICE.DWG		



# STANDARD DETAIL

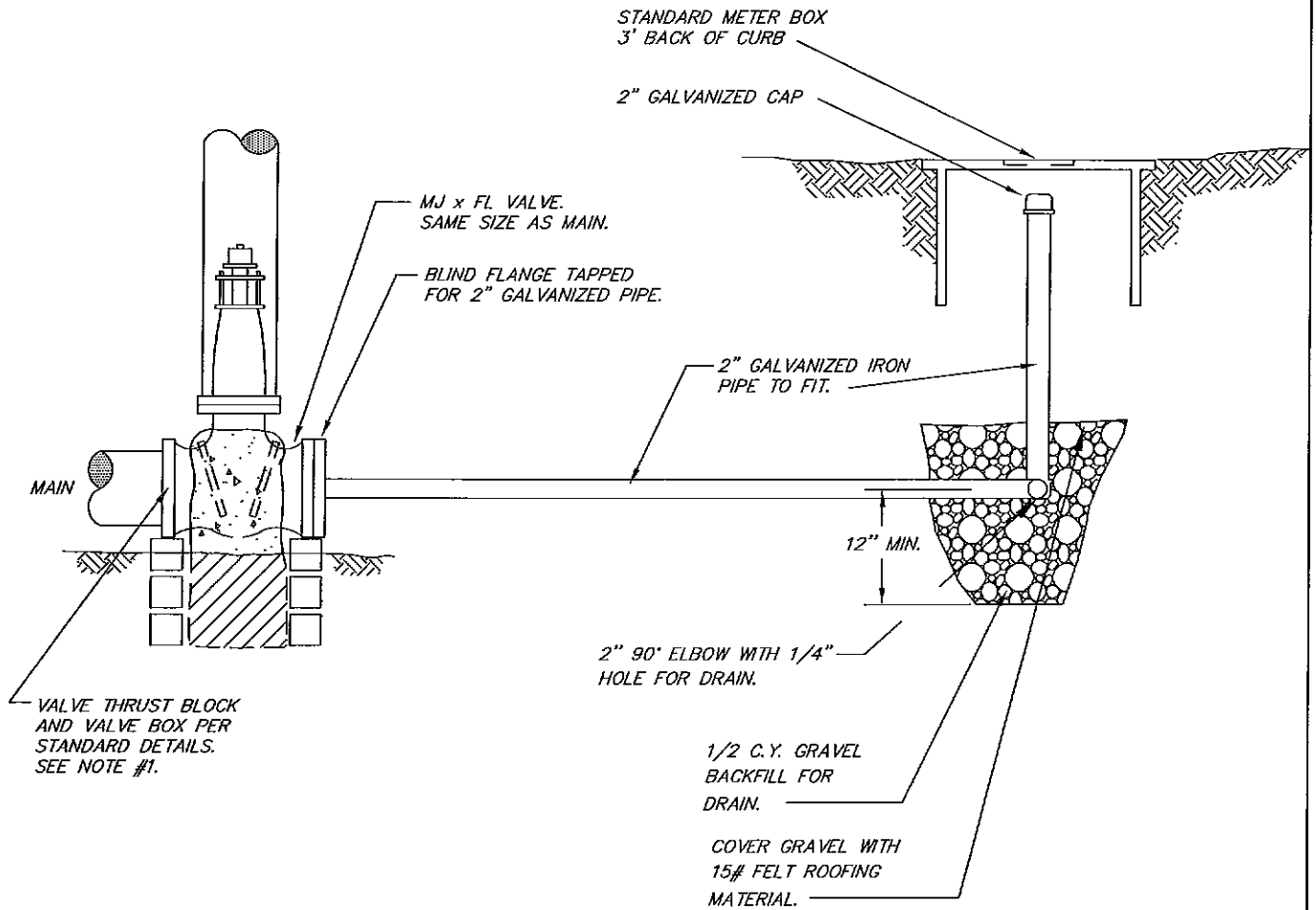

**NOTE:**

1. BLIND FLANGE FOR FUTURE MAIN EXTENSION SHALL BE CLEAN OF THRUST BLOCK CONCRETE.

ALL WORK AND MATERIAL TO BE IN ACCORDANCE WITH THE CURRENT WASHINGTON STATE DEPARTMENT OF TRANSPORTATION "STANDARD SPECIFICATIONS FOR ROAD, BRIDGE, AND MUNICIPAL CONSTRUCTION"

APPROVED BY  
CITY ENGINEER: *[Signature]*  
FILE NAME: BLOWOFF.DWG

DATE: 10/02/95  
REVISED: 3/15/06

2" BLOWOFF ASSEMBLY



# STANDARD DETAIL

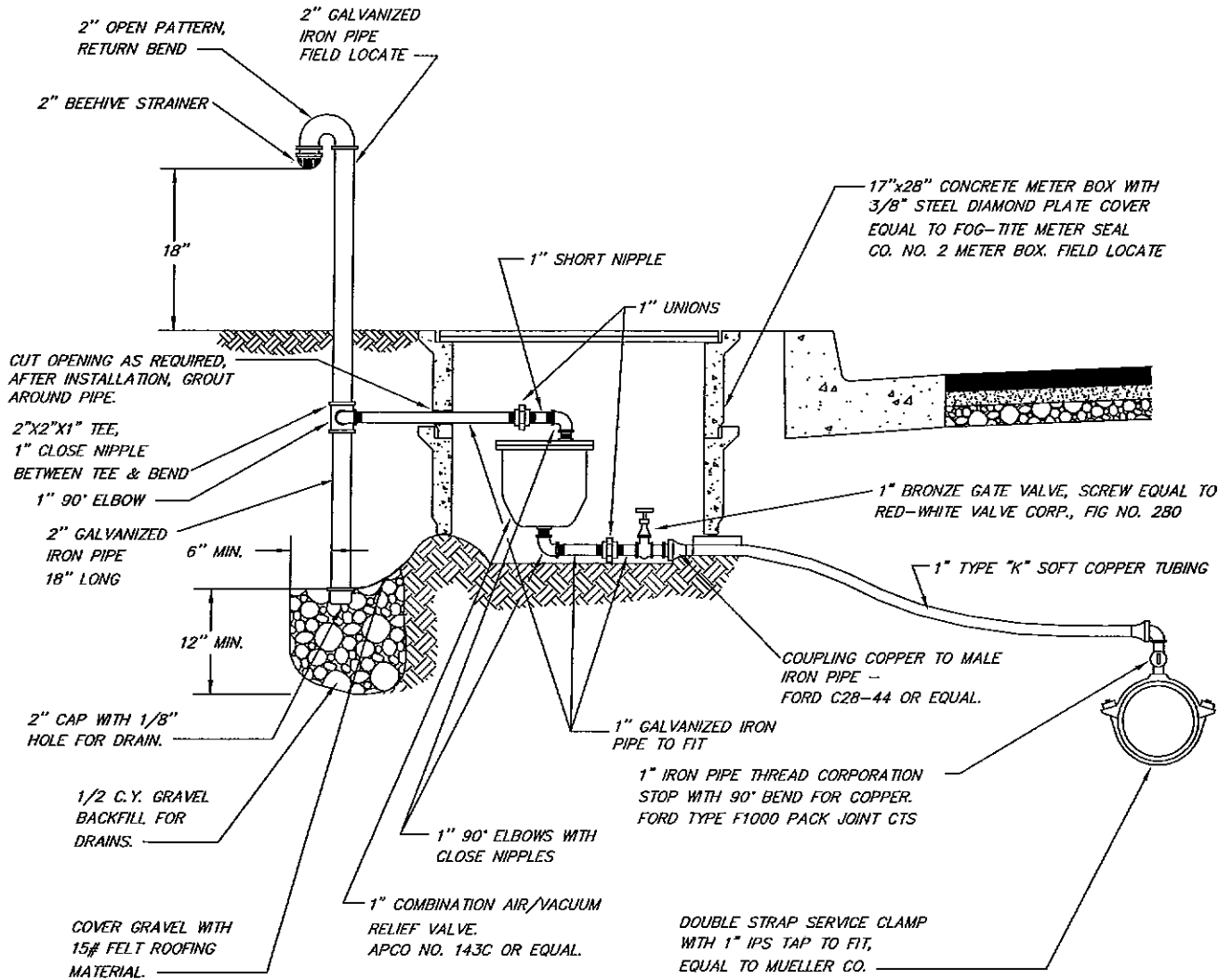

**NOTE:**

1. REQUIRED FOR 12" AND SMALLER MAINS.
2. AIR/VACUUM RELIEF VALVE ASSEMBLY SHALL BE INSTALLED AT HIGHEST POINT OF LINE. IF HIGH POINT FALLS IN A LOCATION WHERE ASSEMBLY CANNOT BE INSTALLED, PROVIDE ADDITIONAL DEPTH OF LINE TO CREATE A HIGH POINT AT A LOCATION WHERE ASSEMBLY CAN BE INSTALLED.

ALL WORK AND MATERIAL TO BE IN ACCORDANCE WITH THE CURRENT WASHINGTON STATE DEPARTMENT OF TRANSPORTATION "STANDARD SPECIFICATIONS FOR ROAD, BRIDGE, AND MUNICIPAL CONSTRUCTION"

APPROVED BY CITY ENGINEER	DATE : 9/08/95 REVISED : 3/15/06	<h2>1" AIR/VACUUM RELIEF VALVE</h2>
FILE NAME: 11AIRRELIEF.DWG		



# STANDARD DETAIL

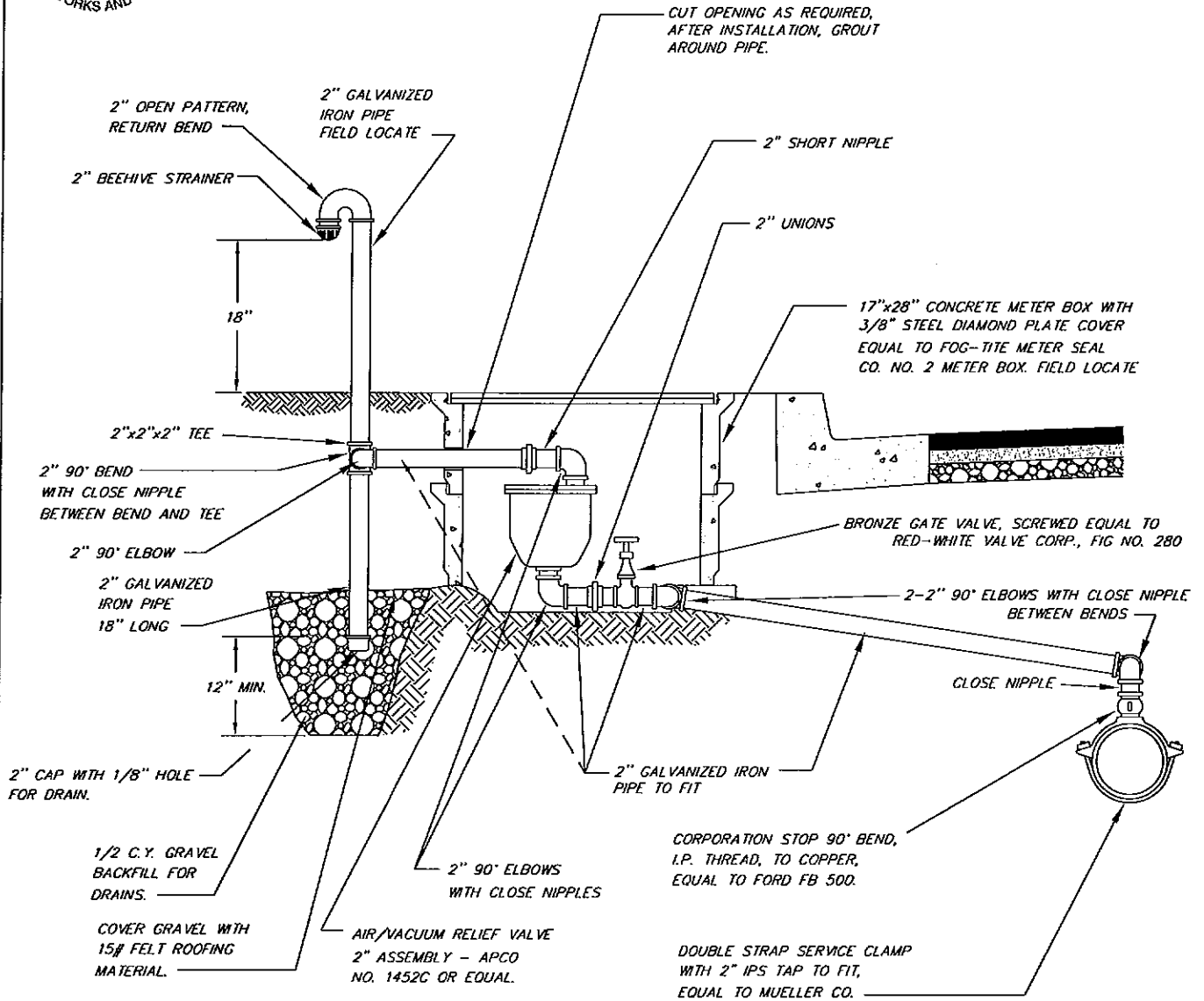

## NOTE:

1. REQUIRED FOR MAINS LARGER THAN 12 INCHES.
2. AIR/VACUUM RELIEF VALVE ASSEMBLY SHALL BE INSTALLED AT HIGHEST POINT OF LINE. IF HIGH POINT FALLS IN A LOCATION WHERE ASSEMBLY CANNOT BE INSTALLED, PROVIDE ADDITIONAL DEPTH OF LINE TO CREATE A HIGH POINT AT A LOCATION WHERE ASSEMBLY CAN BE INSTALLED.

ALL WORK AND MATERIAL TO BE IN ACCORDANCE WITH THE CURRENT WASHINGTON STATE DEPARTMENT OF TRANSPORTATION "STANDARD SPECIFICATIONS FOR ROAD, BRIDGE, AND MUNICIPAL CONSTRUCTION"

APPROVED BY  
CITY ENGINEER

DATE : 9/08/95

REVISED : 3/15/06

FILE NAME: 2INAIRRELIEF.DWG

2" AIR/VACUUM RELIEF VALVE



# STANDARD DETAIL

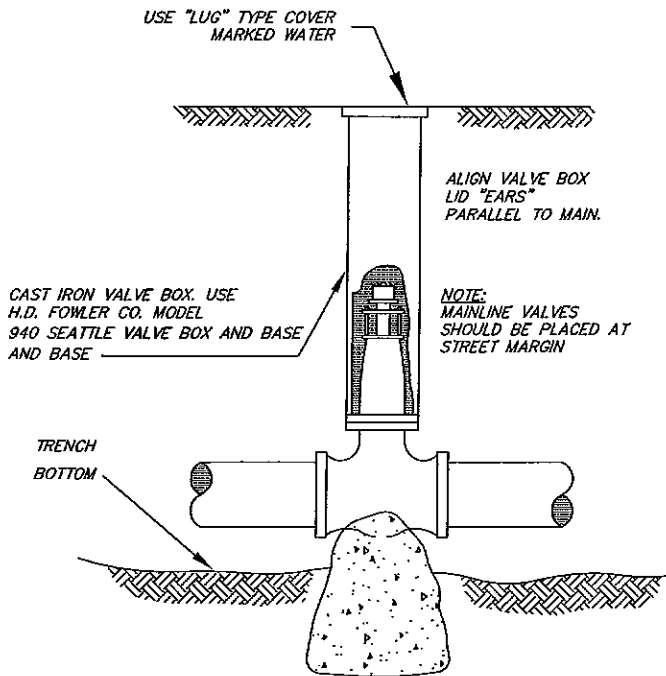

VALVE BOX AND SUPPORT BLOCK

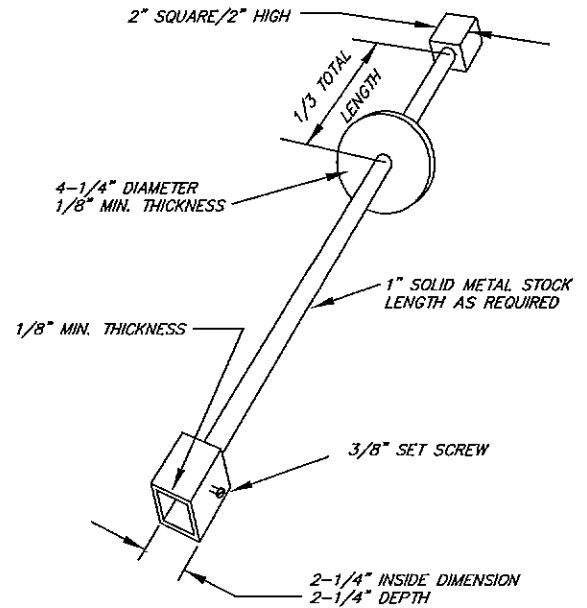

VALVE STEM EXTENSION  
(REQUIRED WHEN DEPTH EXCEEDS 5')

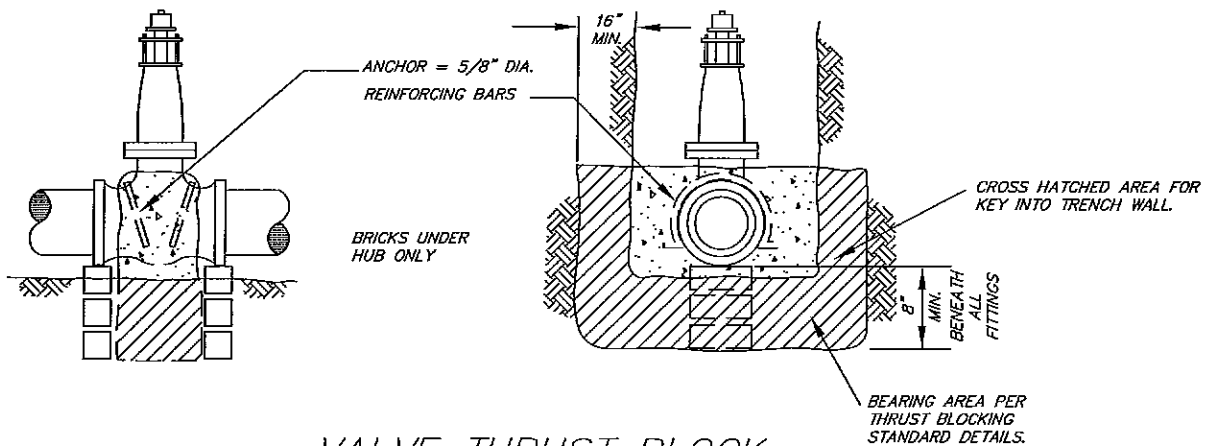

VALVE THRUST BLOCK

**NOTE:**

1. CONCRETE SHALL BE CLASS 3000
2. VALVE THRUST BLOCKS TO BE INSTALLED AT EACH VALVE LOCATION.

ALL WORK AND MATERIAL TO BE IN ACCORDANCE WITH THE CURRENT WASHINGTON STATE DEPARTMENT OF TRANSPORTATION "STANDARD SPECIFICATIONS FOR ROAD, BRIDGE, AND MUNICIPAL CONSTRUCTION"

APPROVED BY  
CITY ENGINEER *[Signature]*  
FILE NAME: GATEVALVE.DWG

DATE : 10/02/95  
REVISED : 3/15/06

VALVE BOX, SUPPORT BLOCK  
AND THRUST BLOCK



# STANDARD DETAIL

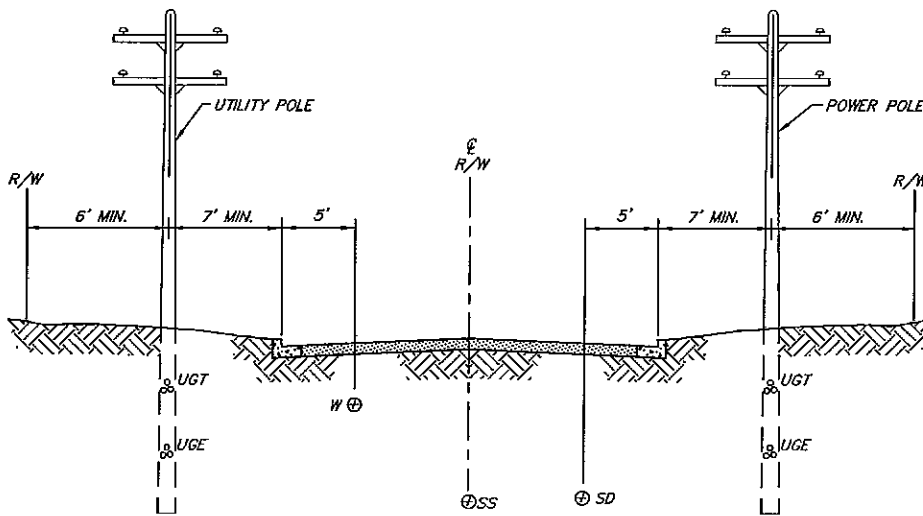

STREET

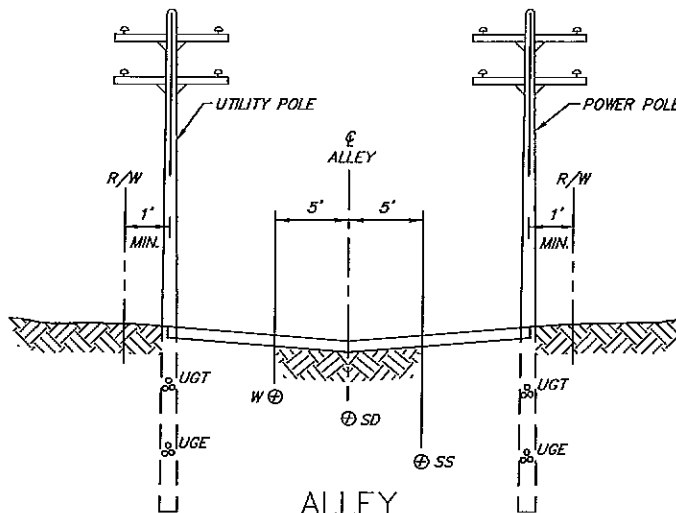

ALLEY

NOTE:

UTILITY/POWER POLE LOCATIONS AT INTERSECTIONS SHALL BE COORDINATED WITH ENGINEERING DIVISION.

SYMBOL	UNDERGROUND SERVICE	MIN. DEPTH
UGE	UNDERGROUND ELECTRICAL PRIMARY/SECONDARY	4'-0"
UGT	UNDERGROUND TV/PHONE	3'-0"
SS	SANITARY SEWER	8'-0"
SD	STORM DRAIN	5'-0"
W	WATER	3'-0"



CALL 48 HOURS  
BEFORE YOU DIG  
1-800-424-5555

APPROVED BY  
CITY ENGINEER: *[Signature]*  
FILE NAME: UTILITYLOCATION.DWG

DATE: 10/03/95  
REVISED: 3/15/06

STANDARD LOCATIONS FOR  
UNDERGROUND UTILITIES



# STANDARD DETAIL

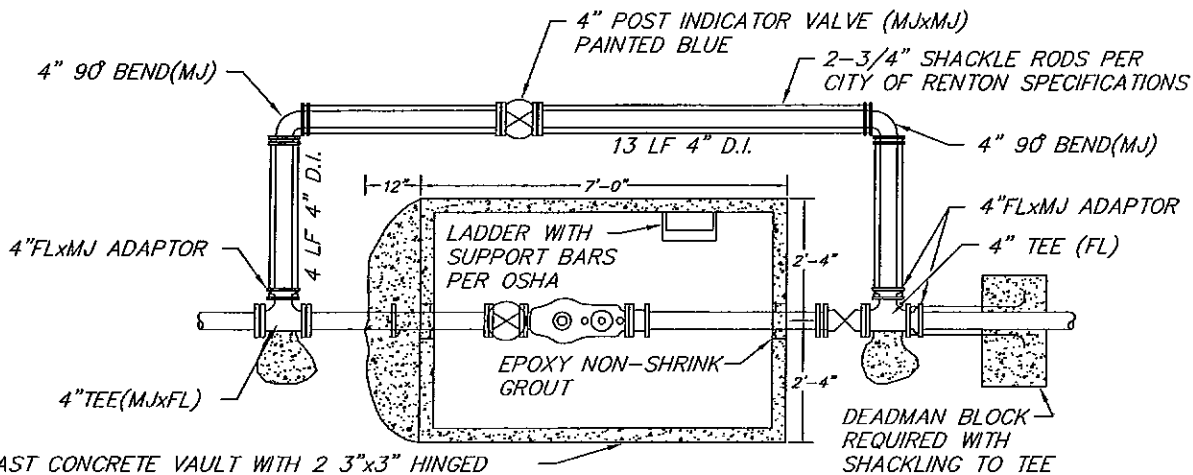

PRECAST CONCRETE VAULT WITH 2 3"x3" HINGED STEEL PLATE COVER. OUTSIDE DIMENSIONS 4'-8"x7'-0". (EUAL TO PIPE INC., OR UTILITY VAULT WITH 57-7L-B, 2 3'x3' DIAMOND PLATE DOORS)

6", 4" OR 3" GATE VALVE (FLxFL)  
NON-RISING STEM WITH HAND WHEEL  
EUAL TO MUELLER CO. A-2380-6.

TWO PIECE CAST IRON VALVE BOX,  
EUAL TO OLYMPIC FOUNDRY CO.  
STANDARD 8" TOP SECTION, WITH  
REGULAR BASE SECTION LENGTH  
TO FIT.

6" OR 4" (FLxPE) CEMENT  
LINED DUCTILE IRON PIPE  
CLASS 52 3'-6" LONG  
WITH COLLAR 20" FROM  
P.E. EUAL TO THOSE  
SUPPLIED BY PACIFIC  
WATER WORKS CO. INC.

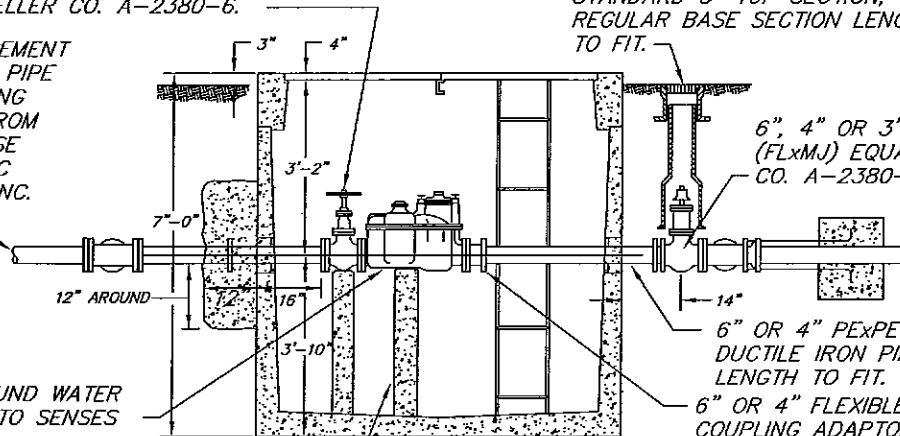

6", 4" OR 3" COMPOUND WATER  
METER (FL) EUAL TO SENSES  
COMPOUND METER.  
REDUCE AT METER WITH  
4"x3" FLxFL CONCENTRIC  
REDUCER.

CONCRETE SUPPORT  
PADS OR ADJUSTABLE  
PIPE SUPPORTS.

6" OR 4" PEXPE CEMENT LINED  
DUCTILE IRON PIPE CLASS 52.  
LENGTH TO FIT.  
6" OR 4" FLEXIBLE FLANGED  
COUPLING ADAPTOR, ROMAC OR  
APPROVED EUAL.

## GENERAL NOTES:

ALL METERS AND BACKFLOW PREVENTION DEVICE COMBINATIONS ARE NOT SHOWN OR INCLUDED IN THE STANDARD DETAIL DRAWINGS. IF YOUR PARTICULAR COMBINATION IS NOT SHOWN, AN APPROVED DRAWING WILL BE REQUIRED BY THE ENGINEERING DIVISION PRIOR TO INSTALLATION. THE PRINCIPAL REQUIREMENTS REGARDING VAULT SIZING ARE THE LENGTH OF FITTINGS OR THEIR CLEARANCE FROM THE VAULT WALLS, (WHICH CLEARANCE SHALL BE A MINIMUM OF 12" FROM THE ENDS AND THE SIDE CLEARANCE SHOULD BE AS TYPICALLY SHOWN ON THE VARIOUS STANDARD DETAILS.)

NOTE: DEADMAN BLOCK SHALL BE DESIGNED AND INSTALLED SO IT BEARS AGAINST SUFFICIENT UNDISTURBED EARTH SO AS TO SUPPORT THE DESIGNED THRUST.

APPROVED BY  
CITY ENGINEER

DATE : 4/19/95

REVISED : 3/15/06

FILE NAME: MASTERMETER.DWG

MASTER  
WATER METER

